



product
CATALOG
2025

AGRINOVA
Ceccato-Mantovani

Trusted partner

Agrinova is a company managed by the Ceccato family since the eighties, committed to maintaining a **direct and personal approach with its clients**. When a customer needs assistance in choosing a product, a spare part, or a service, they **can rely on immediate and human contact**: they will interact directly with a member of our staff, without going through intermediaries.

This approach allows for in-depth communication, understanding specific needs, and **identifying the ideal solution together, highlighting the human connection and mutual trust**.

since 1987

AGRINOVA
Ceccato-Mantovani



New logo for the company: green is the central color of our new logo, symbolizing sustainability and connection to gardening.

We have updated our claim, giving greater prominence to the **"Ceccato-Mantovani"** brand to clearly communicate our identity. The result is a logo that **combines tradition and innovation with a modern, industrial style**, ready to reflect our business growth.

Index

Wood chippers

ZENITH tracked wood chipper	6
ZAKANDRA tracked wood chipper	14
ZAKANDRA drum chipper	22
KOLISFERA hybrid wood chipper	32
ZENIA chipper	36
ZARA chipper	40
ZOE shredder	44

Debris loader & Lawn litter

OLYSSE	50
OTTO	54
OLGA	60
OSWALD	62
OSKAR	68

Power rakes & Scarifiers

JEREMY for tractor	72
JEREMY for tractor	76
JULIO	80
JOSEF self propelled	82
JURGEN	86
JEFF	90

WOOD CHIPPERS

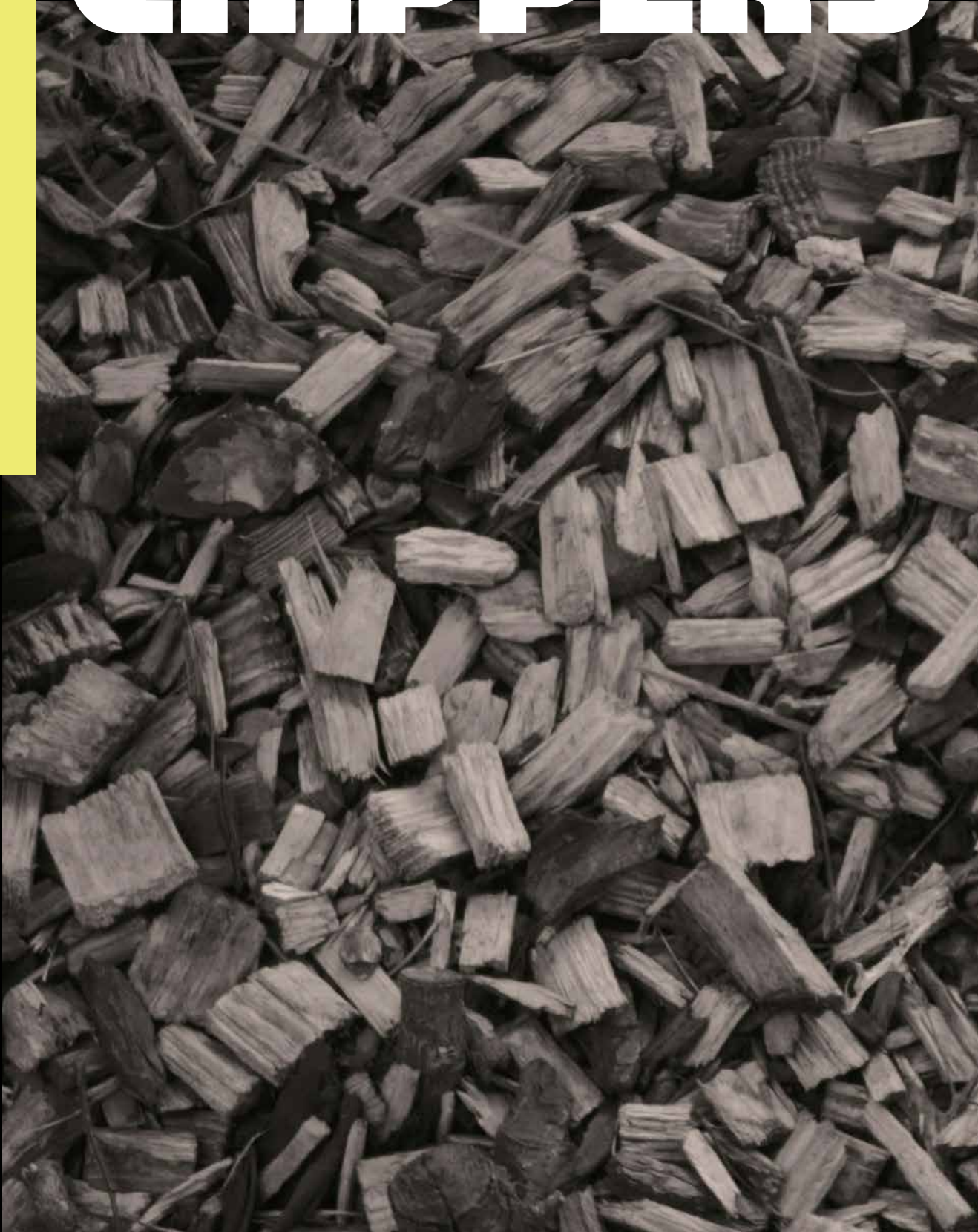



ZENITH

Tracked wood chipper

Cutting up to 15 cm (5,90 inch)



Chipper for gardeners and renters

- on track
- double infeed roller
- drum type cutting system
- suitable also for fibrous material, such as palm tree
- no-stress system

ZENITH

Zenith chipper is designed to quickly and **easily shred plant material** up to 15 cm (5,90 inch) in diameter.

It can be moved very easily and the **pruning point** can be reached without difficulty.



» Strenghths



- › **For easy move on areas with difficult access**, soft ground conditions, or uneven and sloping ground
- › **Ease of loading and unloading** from vans or trucks
- › **Compact size**, you can also load it on small vans (with the hopper folded and the discharge curve lowered, movements are easy)
- › **A single motor to drive track and chipper** to obtain: stability, movement and guide sensitivity, low center of gravity, lower fuel consumption, and reduced maintenanc
- › **Hydraulically driven tracks**, speed up to 2.5 km/h
- › **Compact weight**, 680 kg (tracked version)
- › **Powerful Briggs&Stratton 31 HP Vanguard engine**
- › **Wood and branches cutting up to 15 cm (5,9 inch)**. Can cut fibrous material and prunings
- › **Wide feed hopper**
- › **Easy access** to cutting chamber
- › **Remote radio control** (optional)
- › **SAFETY check of the inclination** of the machine with LUMINOUS alarm and sound and operator's safety

Zenith chipper has been designed to **last over time** and in a **easy to maintain perspective**. Only a few components are subject to wear.



**GOOD FOR
RENTING**

why choose **ZENITH**

power

Briggs & Stratton 31 HP Vanguard professional engine, V-TWIN with electric start.
3 years warranty (Briggs & Stratton).



cutting capacity



Cutting Up to 15 cm (5.9 inch), wood or fibrous material (palm).

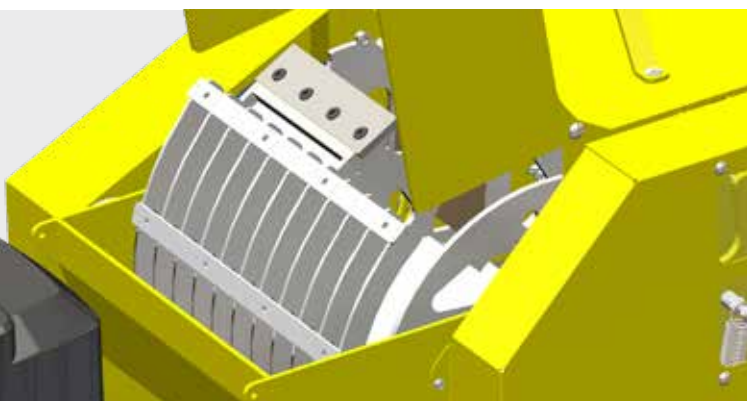

Sieve - 35 mm wide refining screen (optional): to obtain the most suitable wood chip size for your boiler (Wood chipper for biomass boilers).

Drum cutting system with 4 blades. 4 steel plate that rotate at high speed creating the air flow necessary to expel the processed material - even if very wet - at a height of about 2 meters.

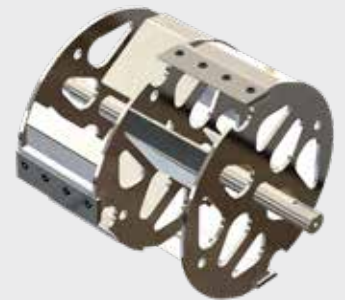

Double feed roller to easy material introduction.



Wide material introduction point.

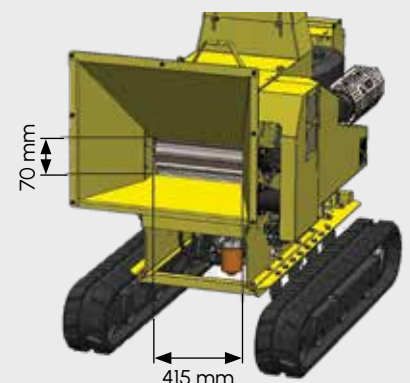

» safety

Agrinova, with **over thirty years of experience**, has taken all the measures that ensure the operator to work in complete safety.



Safety transparent screen.



Great stability thanks to **quality tracks produced in Italy**. 1 mt track.



Emergency/re-start buttons.

» comfort



Anti-clogging system:

The Zenith chipper has a large discharge system that remains wide throughout its extension, avoiding narrowings that block the outgoing material in a bottleneck.

Thanks to the volume of air generated by the rotation of the cutting system, **Zenith is able to easily unload almost all types of shredded material**, even if it is particularly wet or leafy, minimizing clogging and machine stops.



Controls:

2 levers located on the "console" allow separate control of the left and right track.



Possibility of adjusting the feed roller speed

by acting on the flow adjustment knob.



The centrifugal clutch allows the **engine to start without loading the cutting system**.





The movements are facilitated with the hopper folded and the discharge curve lowered.



Max width 1.25 meters.
The Zenith chipper is designed to be easily moved even on narrow paths.



No-stress system has the purpose of preserving the engine from excessive stress originating from the cutting of materials of large diameters, very hard, leafy, humid and, which requires a lot of power.



The two feed rollers, moved by a pair of hydraulic motors ensure the feeding of heavy and leafy logs into the cutting chamber.
The speed is adjustable by a knob on the machine.



Speed regulation and inversion of the feeding roller by means of electric drives and controls.



Thanks to its transparent window, it is possible to see the inside of the cutting chamber without opening it.

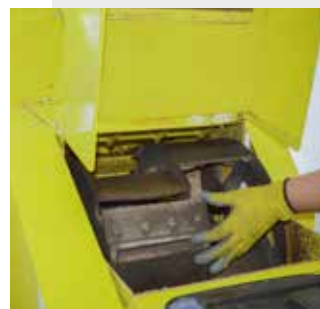

Ease of access to the cutting chamber: Zenith has been designed to be able to quickly and safely access the cutting chamber.



HOUR COUNTER
excellent even in case of vehicle rental.

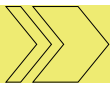

optional



Remote radio control



Tilt control: Zenith can be equipped with a luminous sound alarm for slope control.

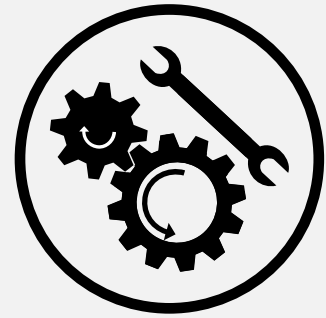

Emergency kit: a kit of spare knives, a belts kit.

Example of shredded product made with a Zenith chipper.

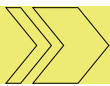

dimensions

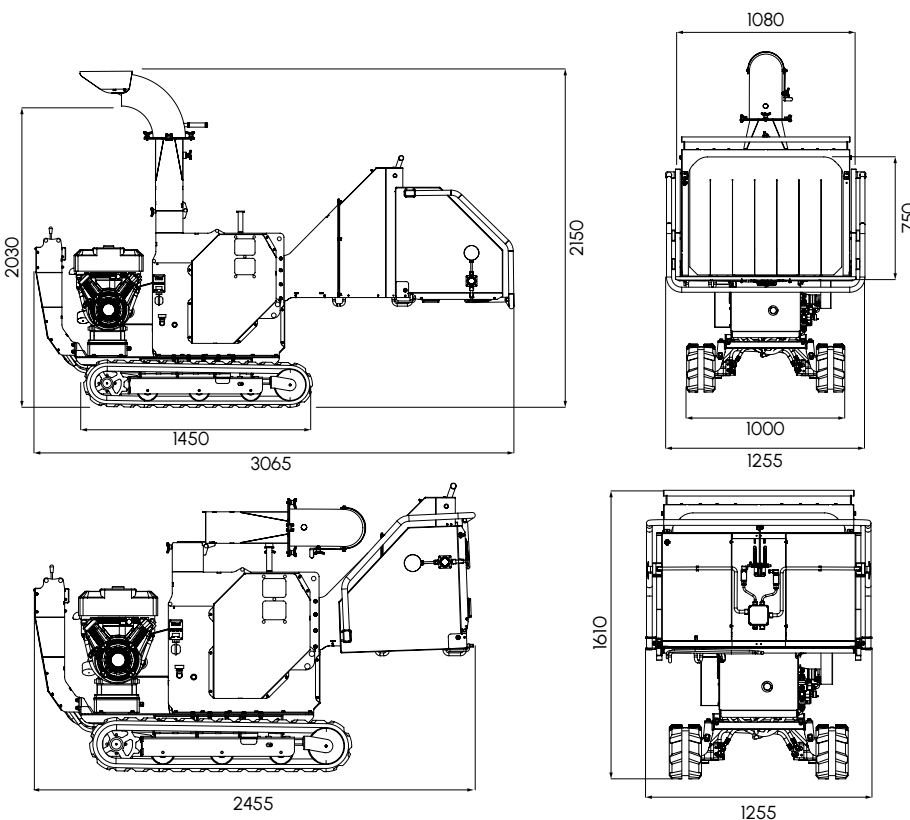

We are working on the versions:

- with Diesel engine
- for tractor
- on street chassis
- rotating turntable
- conveyor roller
- conveyor belt

Transport configuration dimensions

ZH160-B31-AS-C

GENERAL INFORMATION	Max chippable diameter	150 mm (medium hardness wood)
	Work configuration - dimensions	3065 x 1255 x 2 150 h mm
	Transport configuration - dimensions	2455 x 1255 x 1610 h mm
	Weight	720 Kg
	Hopper dimensions (Operator side)	1080 x 750 h mm
	Hopper dimensions (Feed roller side)	415 x 170 h mm
	Hydraulic oil tank capacity	13 l - Spin-on hydraulic oil filter
ENGINE	Type	Briggs & Stratton - Vanguard V-TWIN
	Power	31 HP
	Displacement	Twin 896 cc - air-cooled
	Fuel type	Gasoline
	Tank capacity	15 l
	Start up type	Electric and pull
	Battery	12 V - acid retained - free service
CUTTING SYSTEM	Type	Drum system
	Drum system	50 Kg
	Blades - number	4 and 1 fixed hardened counter-knife
	Transmission	Double belt with centrifugal clutch
	Bearings	Cast iron support bearings
FEEDING SYSTEM	Type	2 counter rotating feed roller
	Control	By safety bar on hopper for stop and reverse By upper safety bar on top of the hopper for stop By restart button on the sides of the hopper for forward
	Transmission	Dedicated hydraulic pump for feed rollers
	No-stress device	Standard equipment - automatic start and stop for feed rollers
DISCHARGE	Type	Tiltable discharge tube - 270° rotation of discharge curve
	Discharge curve dimensions	200 mm diameter
	Control	Adjustable deflector
HANDLING SYSTEM	Type	On track
	Transmission	Dedicated hydraulic pump for each track
	Control	2 lever on rudder - independant lever for each track

ZAKANDRA

Tracked wood chipper

Cutting up to 12 cm (4,72 inch)



Chipper for gardeners and renters

- on track
- double infeed roller
- drum type cutting system
- suitable also for fibrous material, such as palm tree
- no-stress system

ZAKANDRA

Zakandra wood chipper is able to cut **any kind of plant residue, dry or wet**, up to a maximum diameter of 12 cm.

Zakandra offers the possibility of entering **agricultural, wooded areas** and easily overcome the slopes.



» Strenghts



- › **For easy move on areas with difficult access**, soft ground conditions, or uneven and sloping ground
- › **Ease of loading and unloading** from vans or trucks
- › **Compact size**, you can also load it on small vans (with the hopper folded and the discharge curve lowered, movements are easy)
- › **A single motor to drive track and chipper** to obtain: stability, movement and guide sensitivity, low center of gravity, lower fuel consumption, and reduced maintenanc
- › **Hydraulically driven tracks**, speed up to 2.5 km/h
- › **Compact weight**, 680 kg (tracked version)
- › **Powerful Briggs&Stratton 31 HP Vanguard engine**
- › **Wood and branches cutting up to 15 cm (5,9 inch)**. Can cut fibrous material and prunings
- › **Wide feed hopper**
- › **Easy access** to cutting chamber
- › **Remote radio control** (optional)
- › **Safety check of the inclination** of the machine with LUMINOUS alarm and sound and operator's safety

Zakandra chipper has been designed to **last over time** and in a **easy to maintain perspective**. Only a few components are subject to wear.



GOOD FOR RENTING

why choose **ZAKANDRA**

power

Briggs & Stratton 23 HP Vanguard professional engine, V-TWIN with electric start.
3 years warranty (Briggs & Stratton).



cutting capacity



Cutting Up to 12 cm (4,72 inch), wood or fibrous material (palm).



Upper loading hopper: wide material introduction point, dimensions: width 1200 mm; height altezza 430 mm.

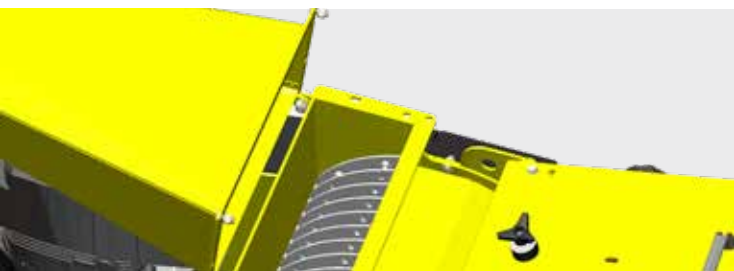

Sieve for chip measure regulation: Zakandra can be equipped with particular sieves that allows to graduate the shredded output in order to obtain chips of an ideal size for the purposes of supply of many Biomass Heating Systems.

Drum cutting system with 4 blades. 4 steel plate that rotate at high speed creating the flow of air necessary to expel the processed material - even if very wet - at a height of about 2 meters.

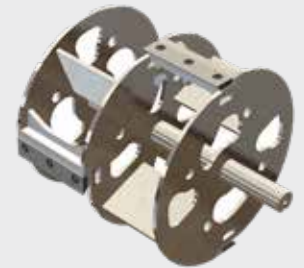

Lower loading hopper: the hopper remains large even at the cutting point, so that the machine is able to shred particularly leafy materials, such as olive trees pruning, avoiding blockages and allowing grinding of large quantities of material for each load.

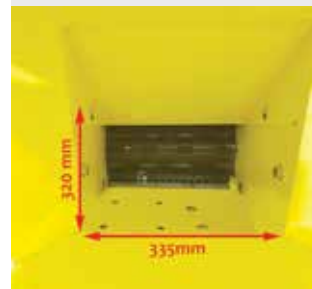

This leads to a significant reduction of working times.

Hydraulic infeed roller is a 190 mm diameter toothed steel roller with adjustable speed and rotation direction; it is placed inside the hopper and carries every kind of vegetable waste automatically towards the cutting system. (roller width 332 mm).



safety

Agrinova, with **over thirty years of experience**, has taken all the measures that ensure the operator to work in complete safety.



Safety transparent screen.



Great stability thanks to **quality tracks produced in Italy**, 1050 mm length; 900 mm track.



Emergency/ re-start buttons.

comfort



Anti-clogging system: it has a large discharge system that remains wide throughout its extension, avoiding narrowings that block the outgoing material in a bottleneck.

Thanks also to the volume of air generated by the rotation of the cutting system, **Zakandra is able to easily unload almost all types of shredded material**, even if it is particularly wet or leafy, minimizing clogging and machine stops.



ROTATION of 360°

Adjustable discharge curve: The discharge curve of the Zakandra chipper is characterized by the possibility of being rotated 360° thus allowing to direct the jet of shredded without having to move the body of the machine. The discharge curve reaches a height of 192 cm from the ground.



Speed regulation and inversion of the feeding roller by means of electric drives and controls.



Palm pruning: Zakandra is the ideal machine also for palm pruning and other particularly fibrous material.



No-stress system has the purpose of preserving the engine from excessive stress originating from the cutting of materials of large diameters, very hard, leafy, humid and, which requires a lot of power.

Easy access to the cutting chamber: the Zakandra chipper was designed so that it can be accessed very easily and quickly but always **in strict compliance with safety regulations**, to all those parts that normally require maintenance, in particular the cutting system and to the transmission mechanisms and **to monitor how the machine is working.**



Controls: 2 levers located on the "console" allow separate control of the left and right track.

Feed roller speed adjustment: Changeover of the feed roller by means of electric drives and controls.



HOUR COUNTER
excellent even in case of vehicle rental.

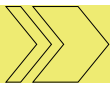

optional



Tilt control: Zakandra can have a LUMINOUS sound alarm that is activated when dangerous inclinations are reached for the stability of the machine both longitudinally and transversally.



Discharge curve extension: allows the drain to be raised by 23 cm (up to a total height of 2.15 m) - Cod. B41892.

Example of shredded product made with a Zakandra chipper.

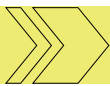

dimensions

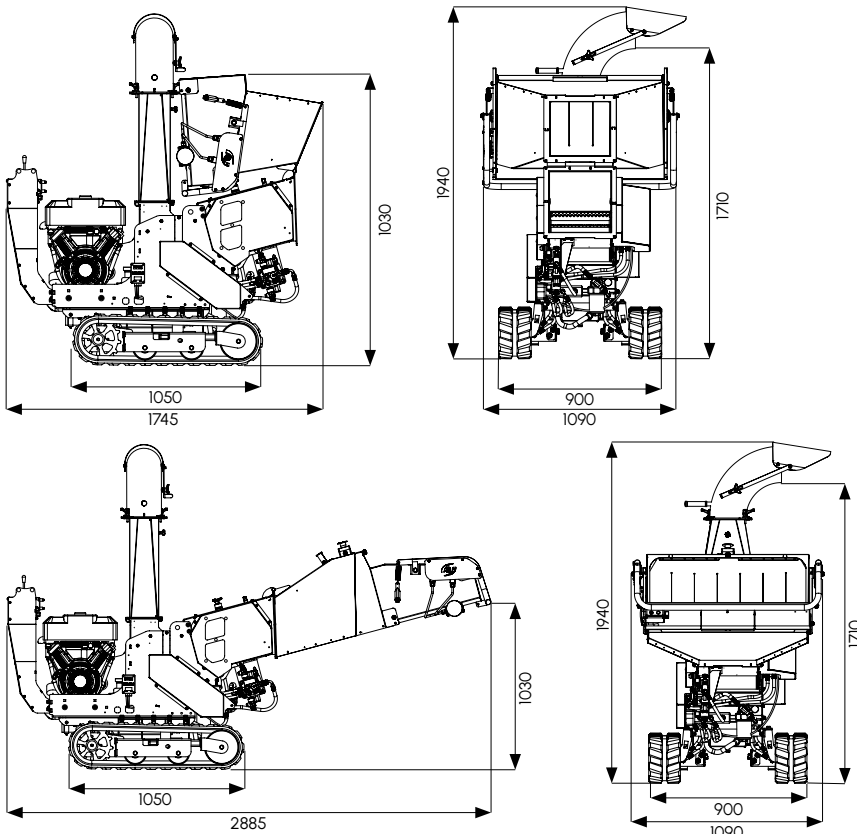

Space management: Zakandra has been designed considering the need to take up little space, in vans and storage. Hopper and discharge are closable.



technical data

ZA350-B2-AS-TL1-C

GENERAL INFORMATION	Max chippable diameter	120 mm
	Work configuration - dimensions	2900 x 1090 x 1960 h mm
	Temporary moving - dimensions	2400 x 1090 x 1960 h mm
	Transport configuration - dimensions	1750 x 1090 x 1960 h mm
	Weight	about 550 kg
	Hydraulic oil tank capacity	12 Litres (with filter and pressure gauge)
ENGINE	Type	Briggs & Stratton - Vanguard
	Power	23 HP
	Displacement	Twin cylinder
	Cooling	Air cooled
	Start up type	Electric
	Fuel type	Gasoline
	Tank capacity	8,5 l
CUTTING SYSTEM	Type	Drum system
	Blades - number	2+2 knives + fixed counterknife
	Blades - materials	Core hardened steel
	Transmission	Double belt with centrifugal clutch
	Width	335 mm
FEEDING SYSTEM	Upper roller	Toothed, hydraulic steel, diameter 190 mm
	Lower roller	Smooth, nylon, folle diameter 80 mm
	Trasmissione	Idraulica - pompa dedicata per i rulli di avanzamento
	No-stress device	Di serie - Con conta-ore integrato
	Plumbing	Fixed flow pump with electromechanical flow controller
LOADING HOPPER	Dimensions (at chipping point)	335 x 270 mm
	Dimensions	960 x 425 mm
DISCHARGE	Type	360° rotation of discharge curve
	Control	Adjustable deflector
HANDLING SYSTEM	Type	On track
	Transmission	Hydraulic motors
	Track - length	1050 mm
	Track - width	900 mm
OPTIONAL	Sieve	✓ (width 25 mm)
	Raised discharge curve	✓
	Remote radio control	✓
	Slope control	✓

ZAKANDRA

Drum chipper

Cutting up to 12 cm (4,72 Inch)



Professional wood chipper for gardening, agriculture and rental

- with **infeed roller**
- **drum type cutting system**
- also suitable for **palm tree**
- **no-stress system**
- available on street chassis and for tractor

ZAKANDRA

Zakandra wood chipper is able to cut any type of **plant residue, dry or wet, up to a maximum diameter of 12 cm.**

Zakandra offers the **possibility of entering agricultural, wooded areas** and easily overcome the slopes.



» Strengths



- › Zakandra can easily chip every kind of vegetable waste, dry or wet, up to 12 cm max
- › The infeed hopper is wide both in the introduction area and in the cutting point, ensuring ease of work for the operator
- › In case of big volumes of pruning: optional "TL" wider infeed hopper
- › Hydraulically driven tracks, speeds up to 2.5 km/h
- › It is designed for an easy access to maintenance areas
- › Easy moving, thanks to the shape and the weight (350 kg)
- › The shape of the discharge curve allows an easy and immediate material expulsion, without clogging
- › Zakandra produces homogeneous chips, with a quality that allows them to be used in many boilers.

Zakandra chipper has been designed to **last over time** and in a **easy to maintain perspective**. Only a few components are subject to wear.



**GOOD FOR
RENTING**

why choose **ZAKANDRA** *on wheels*

power

Briggs & Stratton 23 HP Vanguard professional engine, V-TWIN with electric start.
3 years warranty (Briggs & Stratton).



cutting capacity



Cutting Up to 12 cm (4,72 inch) wood or fibrous material (palm).

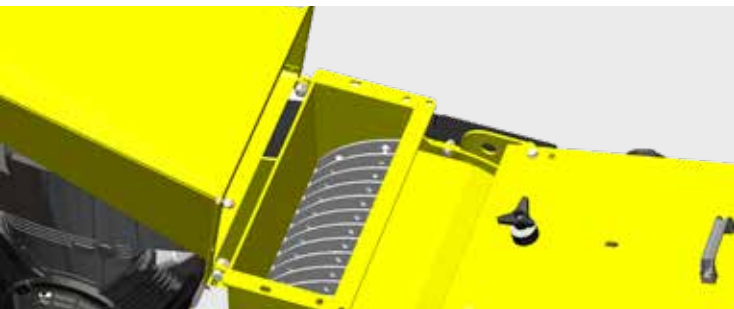

Sieve for chip measure regulation: Zakandra can be equipped with particular sieves that allows to graduate the shredded output in order to obtain chips of an ideal size for the purposes of supply of many Biomass Heating Systems.

Drum cutting system with 4 blades. 4 steel plate that rotate at high speed creating the flow of air necessary to expel the processed material - even if very wet - at a height of about 2 meters.

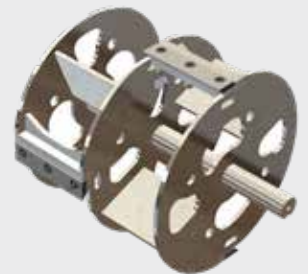

Lower loading hopper: the hopper remains large even at the cutting point, so that the machine is able to shred particularly leafy materials, such as olive trees pruning, avoiding blockages and allowing grinding of large quantities of material for each load. This leads to a significant reduction of working times.

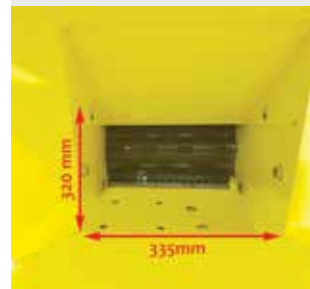

Hydraulic infeed roller is a 190 mm diameter toothed steel roller with adjustable speed and rotation direction; it is placed inside the hopper and carries every kind of vegetable waste automatically towards the cutting system. (roller width 332 mm).



Three types of hopper

Closable hopper (version "TL1") with electrical controls of the power supply system and emergency/restart button. This is only available in the models with nostress device. **This is not an optional**

1 Standard version

700 x 565 mm



2 "TL" version (optional)

1150 x 885 mm



3 "TL1" version (optional)

1200 x 430 mm



safety

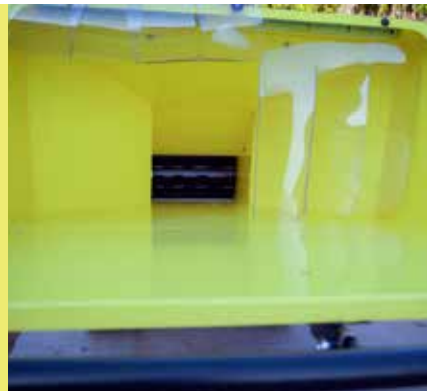

Safety transparent screen.



Emergency/ re-start buttons.

Agrinova, with **over thirty years of experience**, has taken all the measures that ensure the operator to work in complete safety.

optional



Discharge curve extension: allows the drain to be raised by 23 cm (up to a total height of 2.15 m) - Cod. B41892.



No-stress system: it is a device that protect gasoline engine from excessive stress originating from the cutting of materials of large diameters, very hard, leafy, humid and, which in general require a lot of power.

HOUR COUNTER

Excellent even in case of vehicle rental.



*Only for version with hopper "TL1"

Speed regulation and inversion of the feeding roller* by means of electric drives and controls.



Palm pruning: Zakandra is the ideal machine also for palm pruning and other particularly fibrous material.

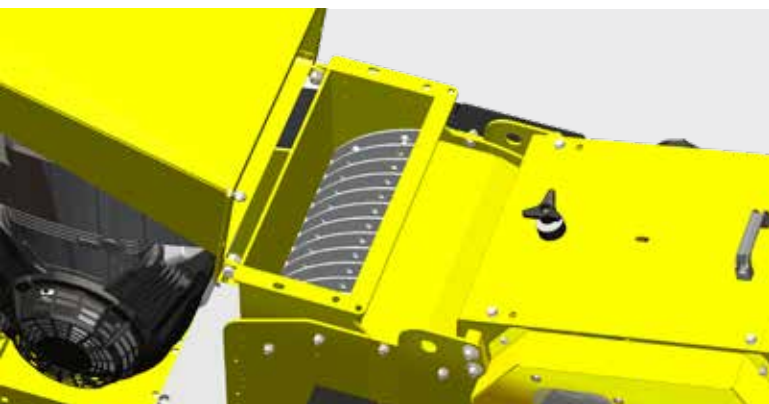

Sieve for chip measure regulation (with 20 mm or 25 mm slit): Zakandra can be equipped with particular sieves that allows to graduate the shredded output in order to obtain chips of an ideal size for the purposes of supply of many Biomass Heating Systems.

Easy access to the cutting chamber: the Zakandra chipper was designed so that it can be accessed very easily and quickly but always **in strict compliance with safety regulations**, to all those parts that normally require maintenance, in particular the cutting system and to the transmission mechanisms and **to monitor how the machine is working.**



ROTATION of 360°

Adjustable discharge curve: it is characterized by the possibility of being rotated 360° thus allowing to direct the jet of shredded without having to move the body of the machine. The discharge curve reaches a height of **192 cm from the ground.**

Feed roller speed adjustment.* Changeover of the feed roller by means of electric drives and controls.

*Only for version with hopper "TL1"



comfort



Anti-clogging system:
it has a large discharge system that remains wide throughout its extension, avoiding narrowings that block the outgoing material in a bottleneck.

Thanks also to the volume of air generated by the rotation of the cutting system, **Zakandra is able to easily unload almost all types of shredded material**, even if it is particularly wet or leafy, minimizing clogging and machine stops.

on street chassis

Zakandra with foldable hopper with electric controls and road trolley with COC approved for biotriturator.

Hydraulic system: fixed flow pump with electromechanical flow regulator

cod. ZA350-B2-AS-SO-TL1



for tractor

For tractors starting from:
30 HP - 540 RPM



dimensions

Space management: Zakandra has been designed considering the need to take up little space, in vans and storage. Hopper and discharge are closable.

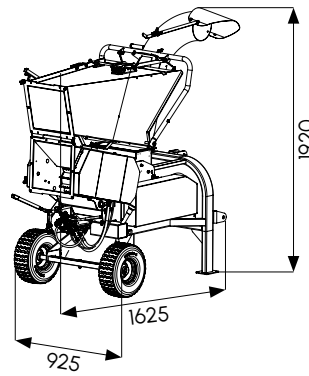
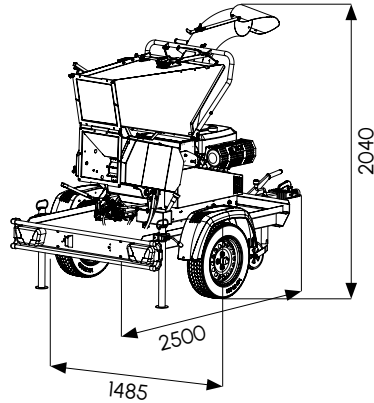
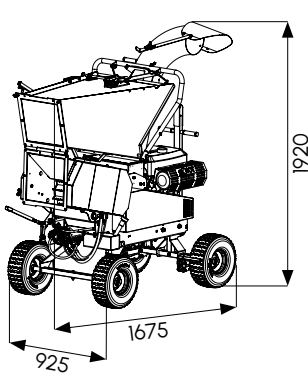

Dimensions at chipping point

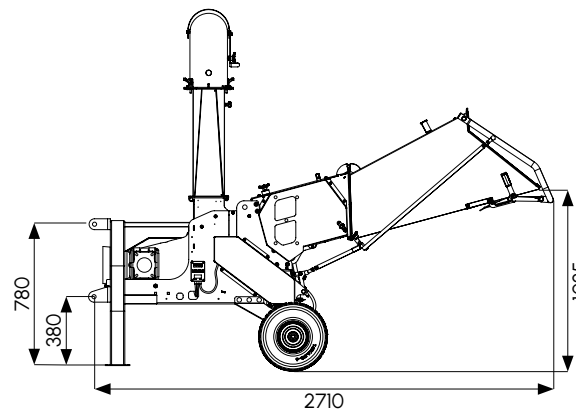
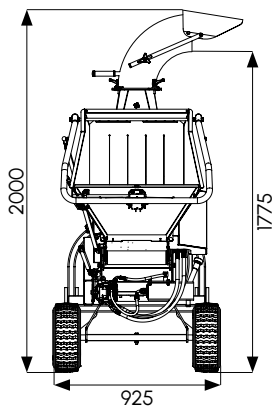
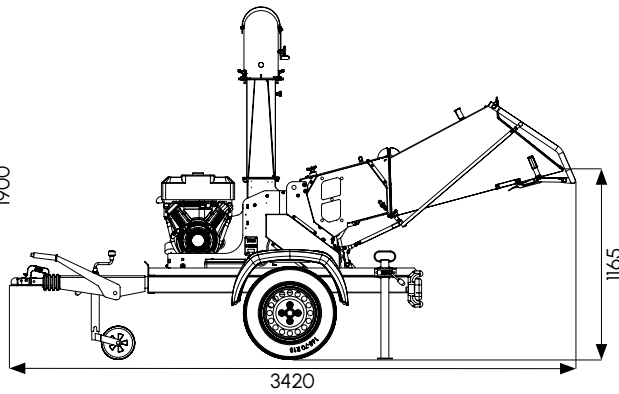
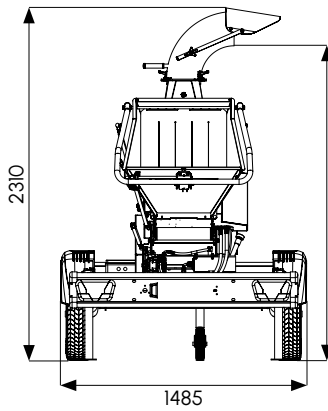
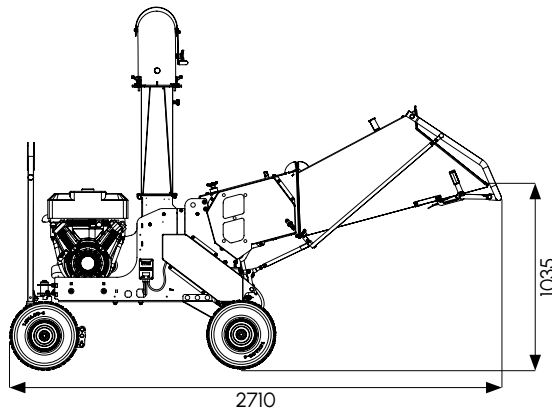
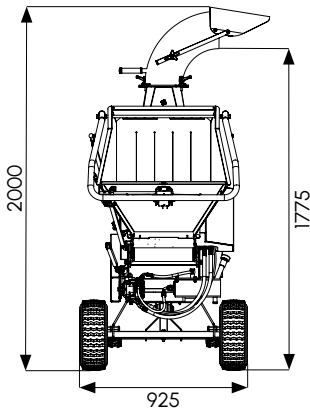
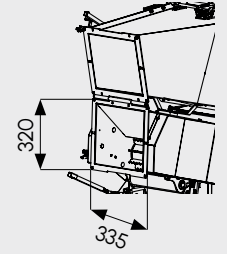

technical data

		ZA350-B & ZA350-B-AS	ZA350-B2-AS
GENERAL INFORMATION	Max chippable diameter	120 mm	120 mm
	Work configuration - dimensions	2710 x 900 x 1920 h mm	2710 x 900 x 1920 h mm
	Transport configuration - dimensions	1780 x 900 x 1750 h mm	1780 x 900 x 1750 h mm
	Weight	370 kg	380 kg
ENGINE	Type	Briggs & Stratton - Vanguard V-Twin	Briggs & Stratton - Vanguard V-Twin
	Power	18 HP	23 HP
	Displacement	Twin cylinder	Twin cylinder
	Cooling	Air cooled	Air cooled
	Start up type	Electric	Electric
	Fuel type	Gasoline	Gasoline
CUTTING SYSTEM	Type	Drum system	Drum system
	Blades - number	2+2 knives + fixed counterknife	2+2 knives + fixed counterknife
	Blades - materials	Core hardened steel	Core hardened steel
	Transmission	Double belt with centrifugal clutch	Double belt with centrifugal clutch
	Width	335 mm	335 mm
FUEL SYSTEM	Roller	Hydraulic	Hydraulic
	Diameter	190 mm	190 mm
	No-stress device	No for Za350-B Standard for ZA350-B-AS	Standard
	Plumbing	Fixed flow pump with electromechanical flow controller	Fixed flow pump with electromechanical flow controller
LOADING HOPPER	Dimensions (at chipping point)	335 x 270 mm	335 x 270 mm
	Dimensions infeed hopper	690 x 550 mm	690 x 550 mm
	Dimensions increase infeed hopper	1200 x 880 mm	1200 x 880 mm
DISCHARGE	Type	360° rotation	360° rotation
	Control	Adjustable	Adjustable
HANDLING SYSTEM	Wheels number	4	4
	Type	Pneumatic	Pneumatic
OPTIONAL	Increasehopper kit "TL"	✓	✓
	Refining sieve	✓	✓
	Raised exhaust chute	✓	✓

technical data

		ZA350-E	ZA350-T & ZA350-T-AS
GENERAL INFORMATION	Max chippable diameter	120 mm	80/120 mm (a seconda del trattore utilizzato)
	Work configuration - dimensions	2710 x 900 x 1920 h mm	2560 x 900 x 1920 h mm
	Transport configuration - dimensions	1780 x 900 x 1750 h mm	1780 x 900 x 1750 h mm
	Weight	343 kg	330 kg
ENGINE	Type	-	Per PTO
	Power	400 Volt - 12,5 HP	Starting from 30 HP - 540 rpm
	Displacement	-	-
	Cooling	-	-
	Start up type	Electric	-
	Fuel type	-	-
CUTTING SYSTEM	Type	Drum system	Drum system
	Blades - number	2+2 knives + fixed counterknife	2+2 knives + fixed counterknife
	Blades - materials	Core hardened steel	Core hardened steel
	Transmission	Double belt	2V drive belts and centrifugal clutch
	Width	335 mm	335 mm
FUEL SYSTEM	Roller	Hydraulic	Hydraulic
	Diameter	190 mm	190 mm
	No-stress device	Standard	No for Za350-T/Standard for ZA350-T-AS
	Plumbing	Fixed flow pump with electromechanical flow controller	Fixed flow pump with electromechanical flow controller
LOADING HOPPER	Dimensions (at chipping point)	335 x 270 mm	335 x 270 mm
	Dimensions infeed hopper	690 x 550 mm	690 x 550 mm
	Dimensions increase infeed hopper	1200 x 880 mm	1200 x 880 mm
DISCHARGE	Type	360° rotation	360° rotation
	Control	Adjustable	Adjustable
HANDLING SYSTEM	Wheels number	4	4
	Type	Pneumatic	Pneumatic
OPTIONAL	Increase hopper kit "TL"	✓	✓
	Refining sieve	✓	✓
	Raised exhaust chute	✓	✓

KOLISFERA

Electric crawler chipper

Cutting up to 10 cm (3,94 Inch)



NEW!



Wood chipper for gardeners, professionals and rental companies

- on electric track
- with electric roller
- drum cutting system
- also suitable for cutting the pruning of palm
- no-stress EVO system

» **Strenghts**



- > **Easy movement on the working site**, ability to reach even steep areas
- > **Easy loading and unloading** from vans
- > **Small dimensions**, you can load it even on small vans (with lowered exhaust, the movements are easy)
- > **A single motor** for: drive track and chipper, to achieve stability, motion and driving sensitivity, low centre of gravity, lower fuel consumption, and reduced maintenance
- > Hydraulic track with **speed up to 2.5 km/h**
- > **Weight:** kg 550 (Track version)
- > **Efficient 14 HP Vanguard engine**
- > **Cut wood and brush up to 10 cm** (inch 3,94). Cut plant pruning and fibrous material such as palm
- > **Colour display** with all machine functions and any error messages
- > **Easy access** to the cutting chamber in total safety and **security** for the operator
- > **Periodic maintenance displayed on screen**
- > High sensitivity **electronic joysticks** (for machine handling)

The Kolisfera chipper is designed to **last over time** and with a view of **easy maintenance**. Only a few components are subject to wear.



**PERFECT
FOR THE
RENTAL**

» safety

Agrinova, with **over thirty years of experience** has taken all the measures that ensure the operator to work in complete safety.



Double flexible and transparent PVC panel as **splinter protection**

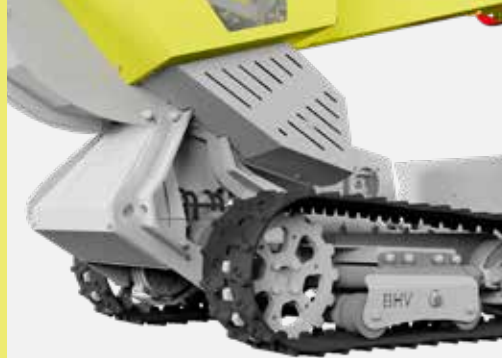

Great stability thanks to **quality tracks produced in Italy**.
Track 870 mm.



Stop/reserve and start/re-start buttons

» comfort



Anti-clogging system: has a large discharge system that remains wide throughout the extension, avoiding bottlenecks that block the material in an outlet bottle neck.

Thanks to the volume of air generated by the rotation of the cutting system, **Kolisfera is able to easily discharge almost all types of shredded material** even if particularly wet or leafy, minimizing clogging and machine stoppages.



Controls by 2 electronic joysticks that allow separate control of the left and right track with high sensitivity

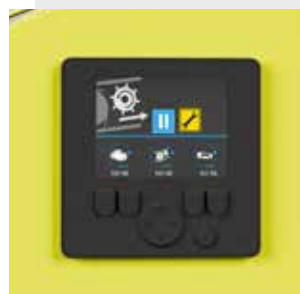

The speed of the feed roller can be adjusted by pressing the appropriate buttons on the display

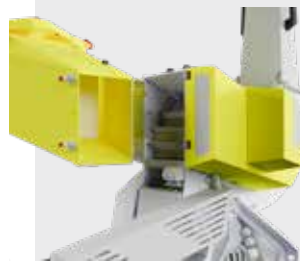

Easy access to the engine for maintenance and refueling

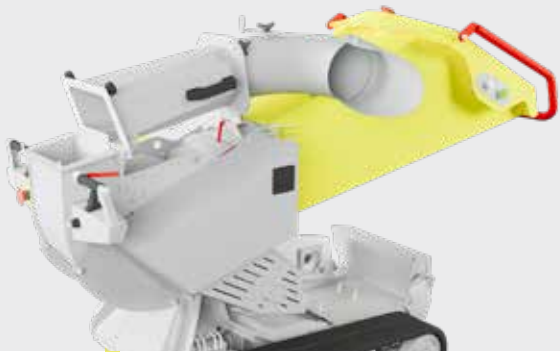

With the exhaust lowered, **displacements are facilitated.**



Maximum width 0.89 m: Kolisfera is designed to be moved easily even on narrow paths.



No-stress EVO system: it aims to preserve the engine from excessive stresses caused by cutting materials of large diameters, very hard, leafy, wet and requiring a lot of power. The LCD display shows the counters for the cutting machine, the heat engine and the electric crawler undercarriage.



The **two toothed rollers**, driven by a pair of hydraulic motors, ensure the feeding into the cutting room of heavy logs and leafy. **The speed is adjustable** by a knob on the machine.

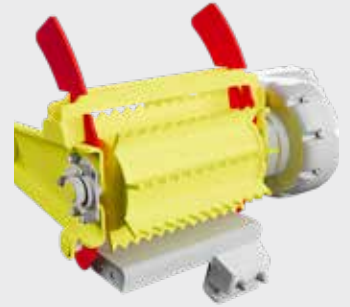

The centrifugal clutch allows the engine to **start without the cutting flywheel load.**



Easy access to the cutting chamber: designed for quick and safe access.



LCD DISPLAY WITH HOUR COUNTER

useful in case of rental of the vehicle.

ZENIA

Chipper

Cutting up to 7 cm



Bio chipper Zenia serie Evolution

- **available version:** petrol engine; tractor pto
- **handling system:** on 2 pneumatic wheels with mudguard and tow hook
- **packaging:** 1 box on pallet (124 x 81 h 110 cm); 1 complete pallet with 2 boxes (124 x 81 h 234 cm); **pto version: 124 x 81 h 116 cm**

why choose **ZENIA**

Its main feature is **ease of use**.
Its principle strength is the **excellent cutting system**.



strenghts



(NEW) Cutting system:

On a front disc of 34 cm in diameter and 10 mm thick, 2 10 cm long knives are mounted, which provide a first reduction in material to be crushed.



At the rear, two sets of hammers, 12 in total, are mounted, which have the function of **deflecting and further reducing the material to be crushed**. Two blades placed on the back of the cutting disc have the function of **creating air and push the shredded material out of the machine through the tube**.

- **Tow hitch:** for easy moovment
- **Exhaust Pipe:** choose the version you need by height
- **Discharge:** standard discharge ride height 125 cm; Exhaust optional ride height 187 cm
- **Discharge chute:** rotatable through 360 ° to select the output direction of the wood chips
- **Double belt transmission:** The transmission of power between the motor and the cutting disc is a double trapezoidal belt that allows an excellent level of rotation fluidity and high motor protection. If the cutting disc is blocked, the belt drive protects against damages and cracks in the crankshaft



A SIMPLE AND RELIABLE SHREDDER

deal for work on small farms and agriturismo sites.

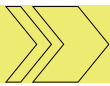

dimensions

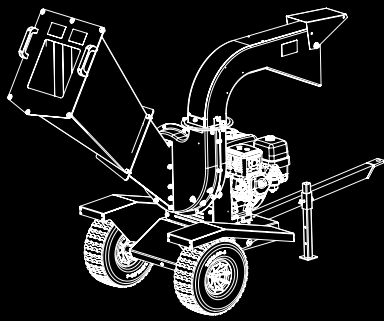

STANDARD VERSION

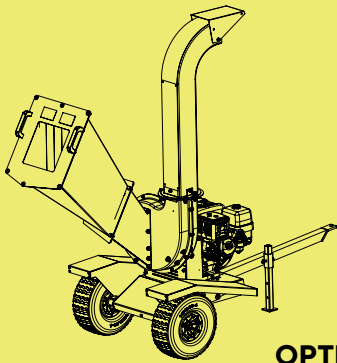
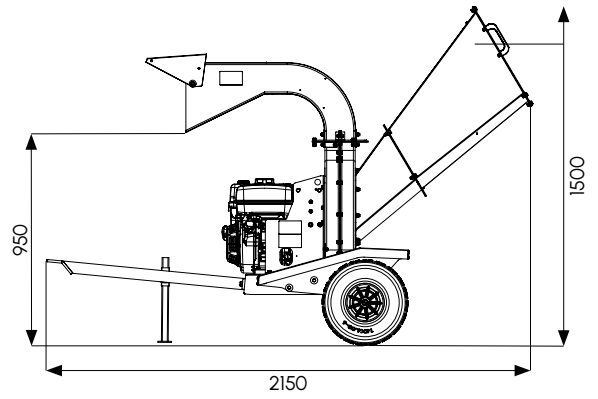
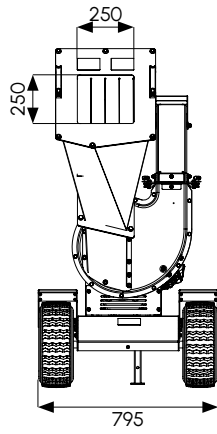

OPTIONAL

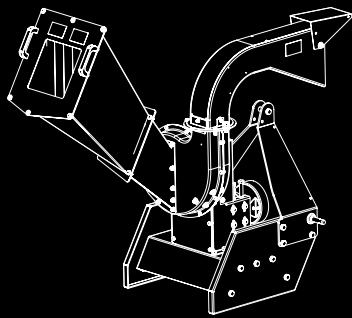
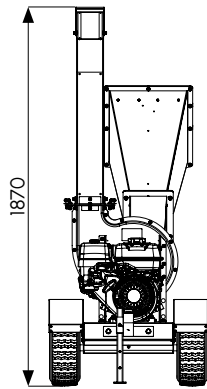

TRACTOR VERSION

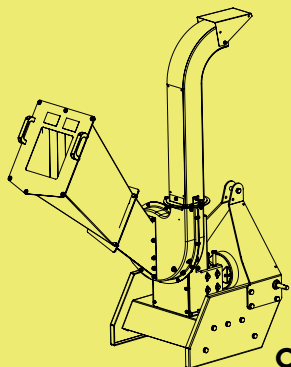
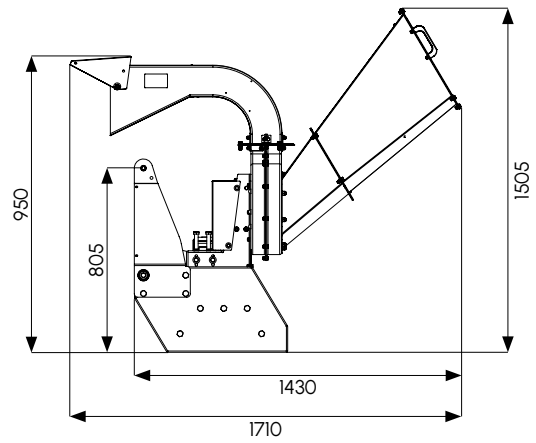
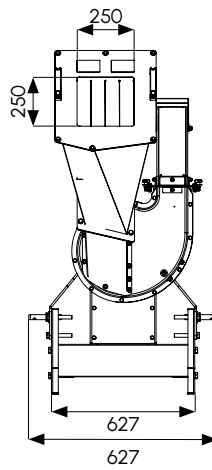

OPTIONAL

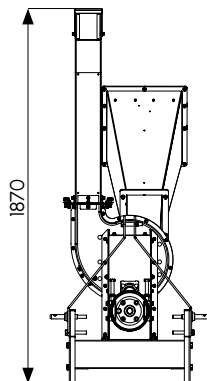

technical data

		ZE400	ZE413-H	ZE400-T1
GENERAL INFORMATION	Max chippable diameter	60-70 mm	60-70 mm	60-70 mm (depending on tractor power)
	Dimensions	2150 x 800 x 1500 h mm	2150 x 800 x 1500 h mm	2150 x 800 x 1500 h mm
	Weight	134 kg	134 kg	131 kg
ENGINE	Type	Briggs & Stratton serie 1450	Honda GX390	Per P.T.O
	Power	9 HP	13 HP	Starting from 16 HP - 540 RPM
	Start up type	Recoil start	Recoil start	-
	Fuel type	Gasoline	Gasoline	-
CUTTING SYSTEM	Type	Disc	Disc	Disc
	Blades - number	2 knives + 14 hammers and blowing blade	2 knives + 14 hammers and blowing blade	2 knives + 14 hammers and blowing blade
	Blades - materials	Tempered steel	Tempered steel	Tempered steel
	Transmission	Double belt	Double belt	Multiplier + Double belt
DISCHARGE	Type	360° rotation	360° rotation	360° rotation
	Standard exhaust chute	125 cm (discharge ride height)	125 cm (discharge ride height)	125 cm (discharge ride height)
HANDLING SYSTEM	Wheels number	2	2	-
	Type	Pneumatic	Pneumatic	-
OPTIONAL	Hopper kit enlarged "TL"	187 cm (discharge ride height)	187 cm (discharge ride height)	187 cm (discharge ride height)



ZENIA ZE400-T1

For tractors starting from 16 HP, 540 RPM

ZARA

Chipper

Cutting up to 7 cm



Bio chipper ZARA light with low centre of gravity

- puncture free wheels and handle
- packaging: 1 box on pallet (95 x 64 h 138 cm)

why choose **ZARA**



Optional pulling handle

strenghts



Cutting rotor: a 376 mm cutting disk is provided with 4 plates to generate the necessary airflow to discharge the chipped material.

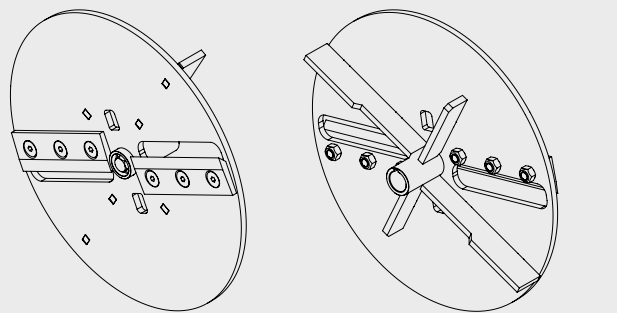

Cutting tool with long-lasting knives

It is equipped with **2 cutting blades**, made of the same high-quality material used for all the Agrinova machines. **Durable performance over time and a precise, easy cut**, even with the most challenging materials to shred, including wet and fibrous material.

- **Able to chip/shred any type of garden waste** up to 7 cm in diameter. Great performance with dry, green branches and fibrous material like the palm tree branches
- **Sieve (optional)** it is at the base of the output port and designed to provide homogeneous finished product
- **Large feeding hopper:** to accept bushy garden waste and large amount of foliage and the feeding hopper is designed with a unique angle to the cutting blade to produce an auto-feeding effect, with least operator intervention
- **High Discharge:** The discharge chute is sufficiently high to discharge the chipped material into a small trailer. A convenient mobile end plate deflector, will direct the discharged material to the most convenient area
- **Handling:** designed with the necessary reinforcements to keep the total weight low, without compromising durability. A characteristic that makes Zara very easy to handle
- **Easy Maintenance:** Designed to easily access to the cutting disk by removing a minimum number of bolts



LIGHT WEIGHT, STRENGTH AND MANOEUVRABILITY

A powerful chipping/shredding machine to clean big volumes of green in small gardens.



The **double V belt** provides the necessary traction to the cutting disk and at the same time act as a **shock absorber to the motor** main shaft in the event the garden waste gets stuck during operation.

The machine is equipped with two 26 cm diameter wheels for easy maneuverability. They are made of puncture-proof technopolymer, allowing the machine **to be used on all types of terrain**.

dimensions

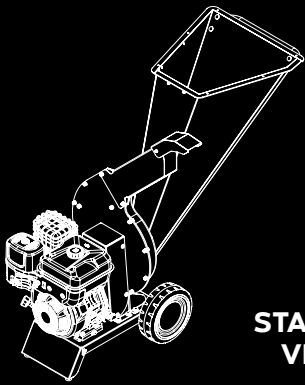

**STANDARD
VERSION**

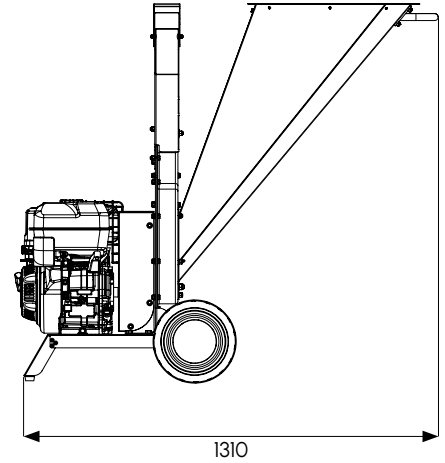
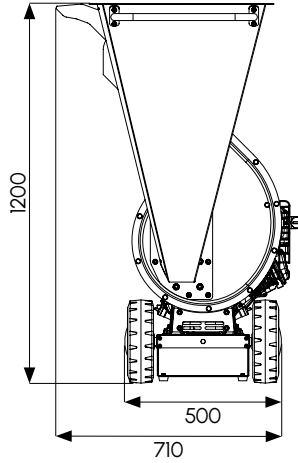

OPTIONAL

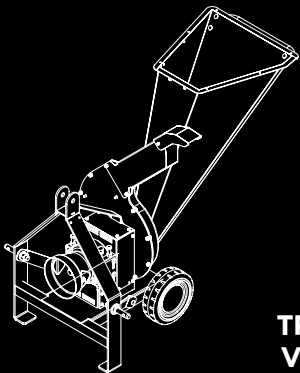
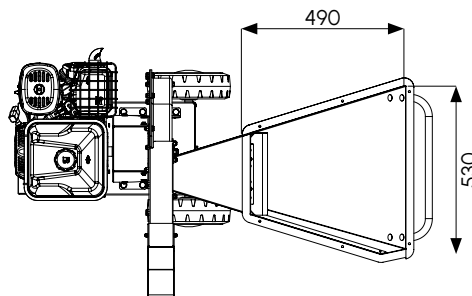

**TRACTOR
VERSION**

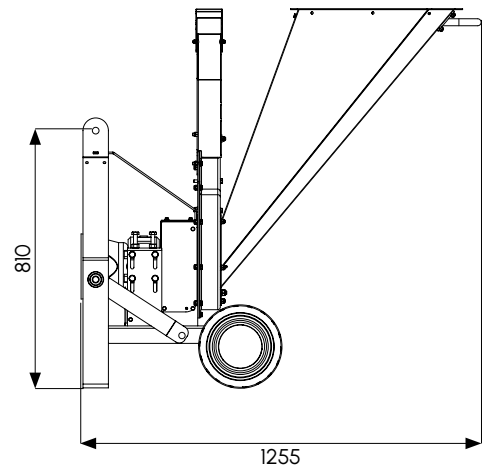
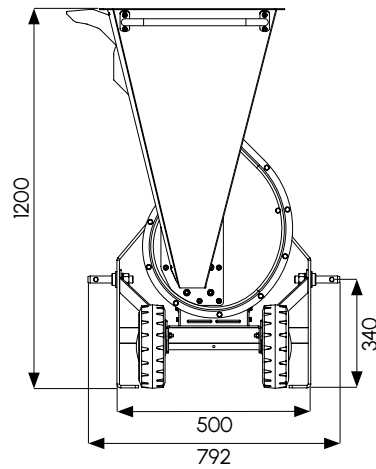

**OPTIONAL
PULLING HANDLE**

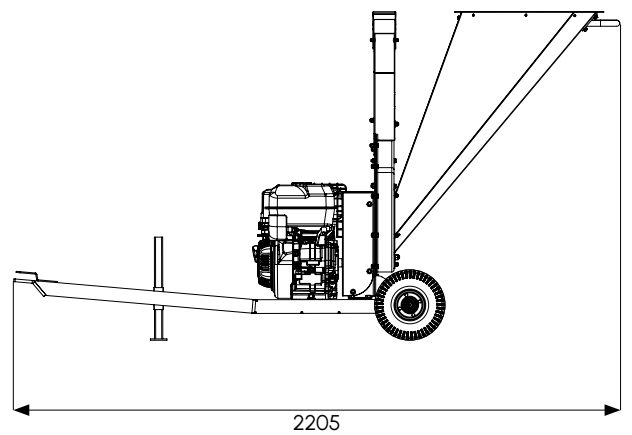
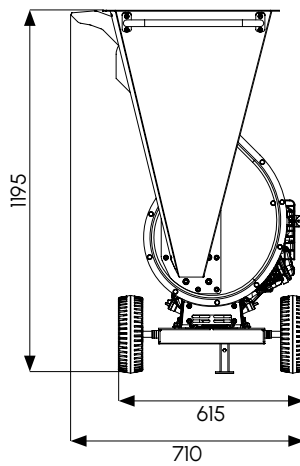

technical data

		ZR80B	ZR80H	ZR80-T
GENERAL INFORMATION	Max chippable diameter	70 mm	70 mm	70 mm
	Dimension (box)	2150 x 800 x 1500 h mm	2150 x 800 x 1500 h mm	2150 x 800 x 1500 h mm
	Weight	95 kg	95 kg	95 kg
	Sieve for regular crushing	✓	✓	✓
ENGINE	Type	Briggs & Stratton serie 1450	Honda GX390	Per P.T.O
	Power	9 HP	9 HP	Starting from 16 HP - 540 RPM
	Start up type	Recoil start	Recoil start	-
	Fuel type	Gasoline	Gasoline	-
CUTTING SYSTEM	Type	Knives	Knives	Knives
	Blades - material	Core hardened steel	Core hardened steel	Core hardened steel
	Transmission	Belt	Belt	Belt
LOADING HOPPER	Max dimensions infeed hopper	510 x 505 h mm	510 x 505 h mm	510 x 505 h mm
DISCHARGE	Type	Pivoting	Pivoting	Pivoting
HANDLING SYSTEM	Wheels number	2	2	2
	Type	Puncture free wheels	Puncture free wheels	Puncture free wheels
	Diameter	260 mm	260 mm	260 mm

OPTIONAL	Pulling handle	✓	✓	✓
-----------------	----------------	---	---	---



ZARA ZR80-T

ZOE

Shredder

Cutting up to 5,5 cm



A robust shredder for working in the garden and orchard

- **puncture free wheels** and handle for easy movements
- **packaging:** 1 box on pallet (700 x 650 h x 900 cm); 1 pallet with 4 boxes (133 x 800 h x 1740 cm)

why choose **ZOE**

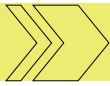

strenghts



Cutting system: on a 6 mm thick disc, two hardened 10 cm front knives are mounted. On the back, there are eight hammers that break down the material, accelerating the decomposition process.

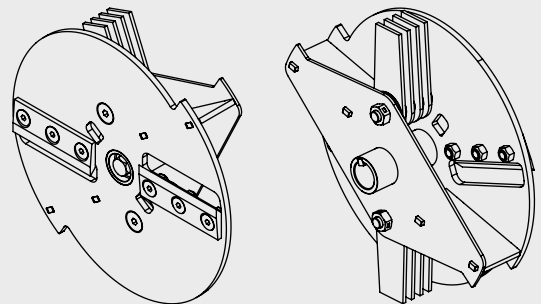

Cutting system with hardened high strength knives

Two counter-blades: one radial and one axial, working together to ensure **uniform wood chip** size and optimal engine power usage during shredding.

- › **Large 25 x 25 cm hopper opening.** It allows for easy pruning input (even for leafy hedges without the need to thin them out first)
- › **Sieve:** fixed near the chamber; it controls the size and uniformity of the chipped material. It can be opened manually, tool-free, to maximize productivity
- › **Large material discharge**
- › **Engine with oil alert,** a device that stops the engine when oil is low, ensuring machine preservation and safe use for third parties (e.g., for rental purposes)
- › **No plastic parts**
- › **Belt transmission system:** protects the engine from the stress of shredding, making this machine particularly robust and durable
- › The sieve allows adjustment of the output **to obtain chips in the ideal size** for feeding various biomass boilers or producing fine wood chips



EASY PRUNING WITH NO PLASTIC PARTS

parts The ideal machine for shredding hedge clippings, orchard, and garden pruning.

dimensions

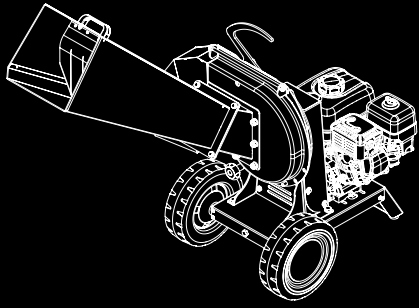

STANDARD VERSION

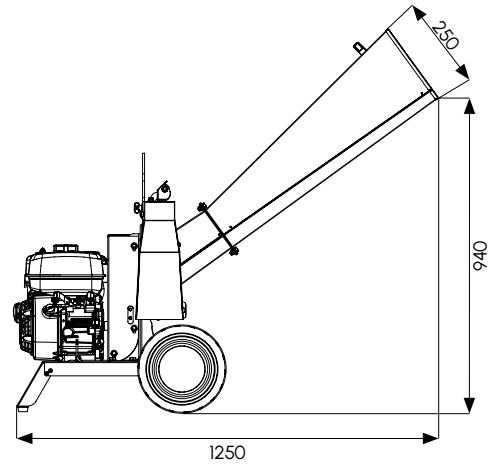
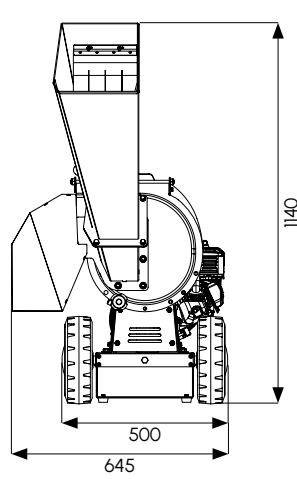

Easy to carry even with small size cars



Example of woodchips with Zoe



For soil care in your garden



For shredding hedge leaves



For shredding orchard prunings



The resulting chips are perfect as mulch (for synergistic gardens, organic and biodynamic farming) and for compost production.

technical data

		ZA50B2-V	ZO50H4-V
GENERAL INFORMATION	Max chippable diameter	50-55 mm	50-55 mm
	Work configuration - dimensions	640 x 1250 x 1550 h mm	640 x 1250 x 1550 h mm
	Dimensions (pallet)	(4 boxes) 1330 x 800 x 1740 h mm	(4 boxes) 1330 x 800 x 1740 h mm
	Weight	60 kg	60 kg
	Sieve for regular grinding	✓	✓
ENGINE	Type	Briggs & Stratton serie 950 Cod. ZO50B2	Honda GP200 Cod. ZO50H4
	Power	6,5 HP	5,5 HP
	Start up type	Recoil start	Recoil start
	Fuel type	Gasoline	Gasoline
CUTTING SYSTEM	Type	Disc	Disc
	Blades - number	2 knives + 8 hammers	2 knives + 8 hammers
	Blades - material	Core hardened steel	Core hardened steel
	Transmission	Belt	Belt
HANDLING SYSTEM	Wheels number	2	2
	Type	Puncture free wheels	Puncture free wheels
	Diameter	260 mm	260 mm

DEBRIS LOA

LAWN LITTER



ADER &

ER



OLYSSE

Debris loader

Olysse has been designed to meet the needs of **municipal, utility companies that deal with road, highway and park cleaning.**



Employers of Agrinova technical office, will assist you on the planning the apply of Vacuum on your truck.



To be applied on

- agricultural trailer
- compactor truck, dump truck, tanks

features



Transmission: double belt transmission and centrifugal clutch



Tube: lightweight, flexible polyurethane with a coiled, antistatic spiral ramata. Length of choice:
A) 5 m - \varnothing 200 mm standard
B) 10 m- \varnothing 200 mm optional

With ergonomic handle; Comfortable tube holder with one wheel (standard) or with two (optional) wheels, code AS8009.

Impeller:

- \varnothing 400 mm
- 6 blades of 10 mm thickness and 155 mm height

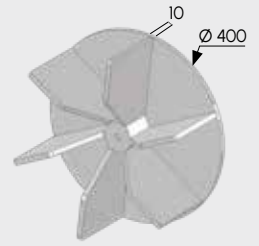

Engagement: suitable for many kinds of side (customized on request)

Housing: steel dual-walled easy to remove

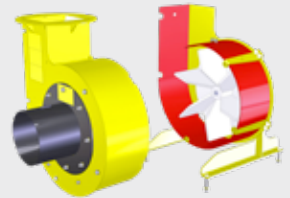

Motor: Powerful electric-start Briggs & Stratton Vanguard 18 hp engine

Discharge hose: 360° Swivelling; adjustable deflector with handleolabile



dimensions

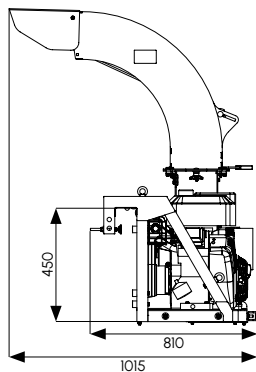
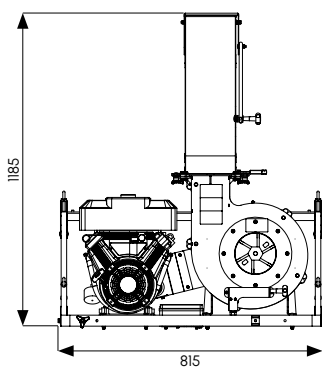

Weight:
170 Kg

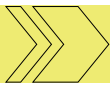

optional



COD. OL1300
Humidifier kit for dust suppressions

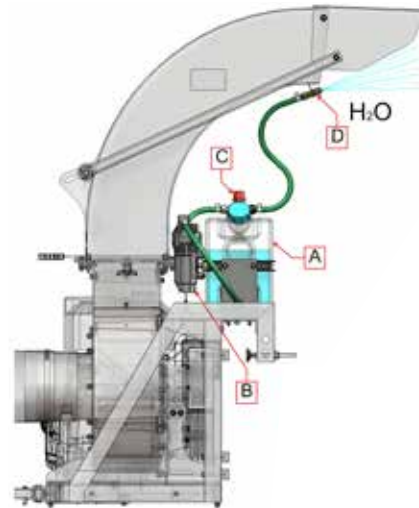
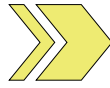

- A** Serbatoio d'acqua
- B** Pompa acqua con interruttore on/off
- C** Regolatore di portata
- D** Ugello



COD. OL950
Manual hydraulic forklift for the lifting and coupling of the side Olysse

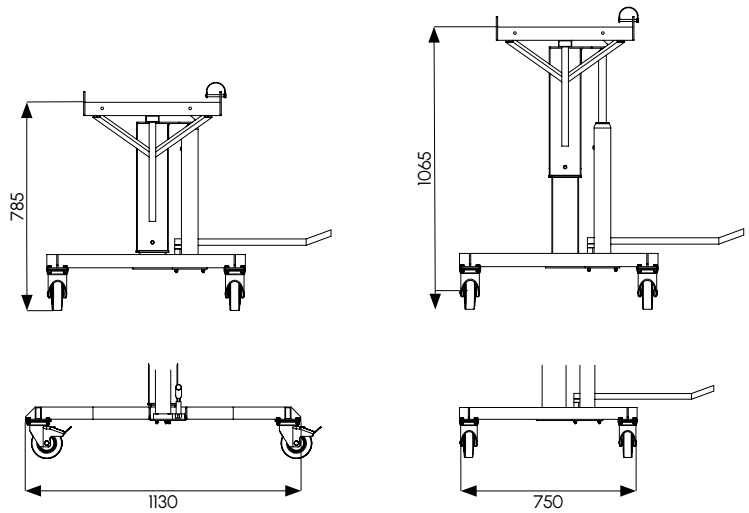

New optional

Adjustment on eight positions

Kit hose holder circular section
diametre 180 mm with 2 wheels
cod. As8009

dati tecnici

		OL13	OL18
GENERAL INFORMATION	Dimensions	1708 x 1093 x 1900 h mm	1708 x 1093 x 1900 h mm
	Weight	170 kg	170 kg
ENGINE	Type	Briggs & Stratton - Vanguard	Briggs & Stratton - Vanguard
	Power	13 HP pullstart	18 HP pullstart
	Displacement	V-Twin	V-Twin
IMPELLER	Diameter	400 mm	400 mm
	Blades	6	6
	Blades - thikness	10 mm	10 mm
	Steel dual-walled	✓	✓
	Safety system with micro-switch	✓	✓
HOSE	Diameter	200 mm	200 mm
	Length	5 m	5 m
	Material	Polyurethane	Polyurethane
	Hose-holder bar	✓	✓
DISCHARGE	Adjustable	360°	360°
TRANSMISSION	Double belt transmission and centrifugai clutch	✓	✓

OPTIONAL	Kit humidifier	OL1300
	Manual hydraulic forklift	OL950
	Kit hose holder with 2 wheels	AS8009
	Kit hose holder squeezed section with 2 wh eels, for hose 180 mm diameter, 35 cmwidth	AS81SC
	Street chassis	Contact us for information



Also available on homologable street chassis (street chassis model of your choice)

OTTO

Debris loader

Otto is a debris loader suitable for cleaning and vacuuming leaves, grass, and light debris from **parking lots, parks, campsites, streets, and courtyards**. Ideal for outfitting compactor vans, it is perfect for urban hygiene and quick clean-ups after events (concerts, carnivals, public gatherings, markets).



Employers of Agrinova technical office, will assist you on the planning the apply of Vacuum on your truck.

features



Tie hook and lift handle: Suitable for many types of tail gates (customizable on request)



Discharge: 360° swivel; adjustable deflector



Hose: polyurethane hose for lightweight, flexibility and excellent wear resistance

- **Polyurethane hose for lightweight,** flexibility and excellent wear resistance
- **length** 5m - ø 180 mm
- **with copper spirai** guarantees antistatic properties
- hose support with **1 wheel** (standard) and with two wheels code AS8004

Impeller:

- Ø 330 mm
- 4 blades 4 mm thickness

The **OT8 model**, the impeller is connected directly to the motor shaft, while for the OT8 / H and OT8 / H2 models, the transmission is belted

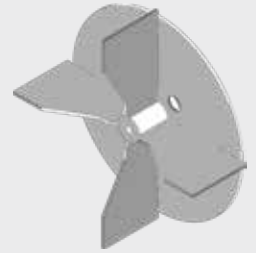

Coated chain and collar support: swivel arm hooked to the chassis frame designed to hold the suction pipe almost weightless for effortless operation

Safety device: limit switch to stop the impeller when the impeller shield is removed.



Base with **3 wheels**

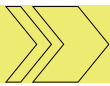

optional

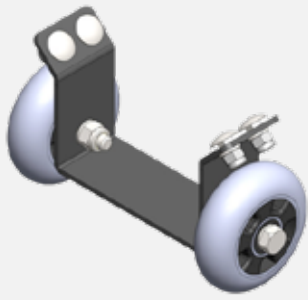

Kit hose holder circular section with 2 wheels **Cod. AS8004**



Steel dual-walled protection for housing **Cod: AS804**

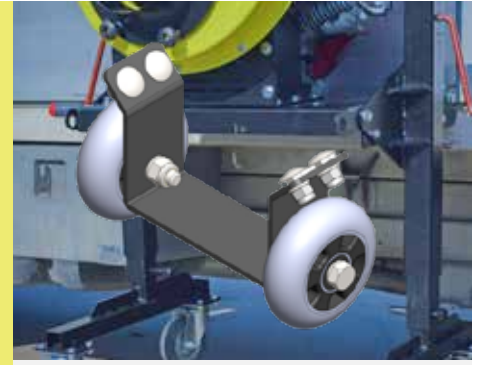

Lifting trolley with mechanical jacks. **Cod: DT490DS (per OT8B) o DT490CS (per OT8H)**

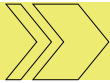

dimensions

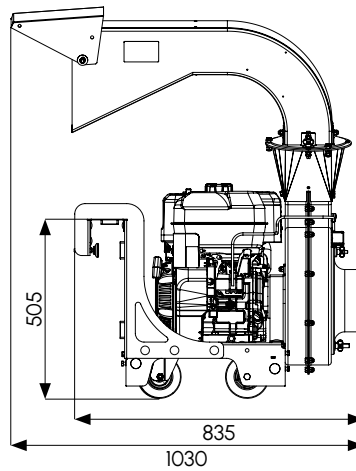
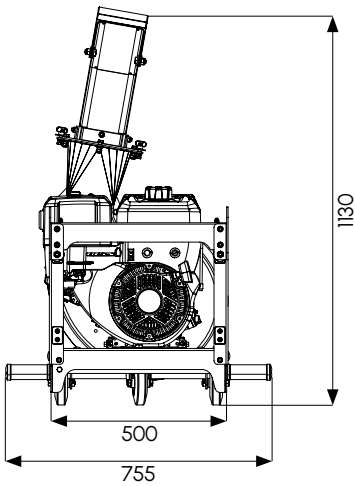

For models with engine **B&S**

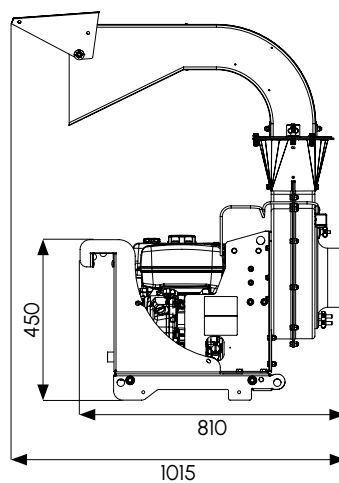
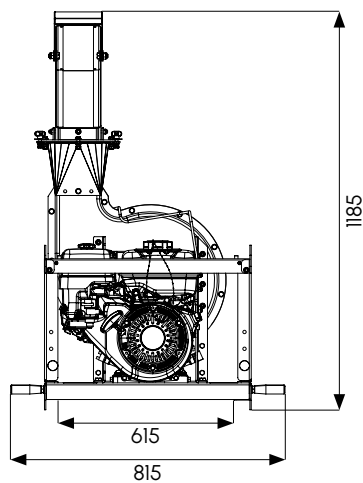

For models with engine **Honda**

technical data

		OT8B	OT8H
GENERAL INFORMATION	Dimensions (box)	800 x 750 x 870 h mm	800 x 750 x 870 h mm
	Weight	97 kg	105 kg
	Base with 3 wheels	✓	-
ENGINE	Type	Briggs & Stratton serie 1450	Honda GX270
	Power	9 HP	9 HP
IMPELLER	Diameter	330 mm	330 mm
	Blades - number	4 welded	4 welded
	Blades - thickness	4 mm	4 mm
	Safety micro switch	✓	✓
HOSE	Diameter	180 mm	180 mm
	Length	5 m	5 m
	Material	Poliuretanic	Poliuretanic
	Hose-holder bar	✓	✓
	Circular section extendable tube bras withawheel	✓	✓
DISCHARGE	Adjustable	360°	360°
TRANSMISSION		Direct	With double belt

OPTIONAL	Lift truck	DT490DS	DT490CS
	Kit hose holder circular section with 2 wheels	AS8004	AS8004
	Kit hose holder squeezed section with 2 wheels, for hose 180 mm diametre, 35 cm width	AS80SC	AS80SC
	Steel dual-walled protection for housing	AS504	AS804

other versions

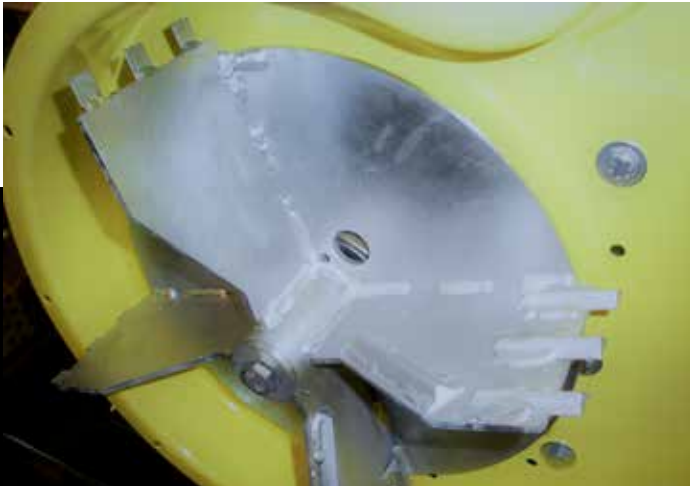

Special Model

With special impeller to shred vacuumed material. Available only for the Honda models



Tractor model (pto)

With safety micro switch. To be connected to the 3 lifting points of 16 HP tractor at 540 rpm (16 or Higher)

For the optional special version and tractor version, see the previous table.

dimensions

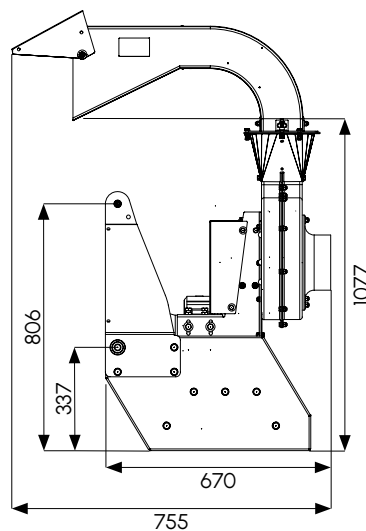
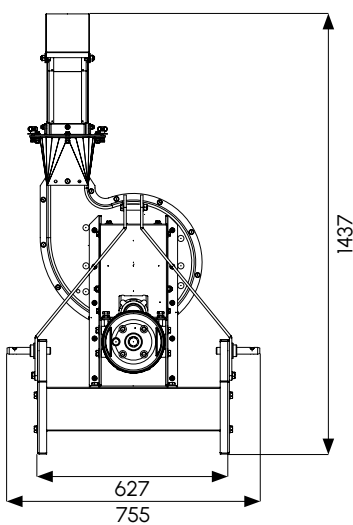

Model for tractor version

technical data

OT8-H2F

GENERAL INFORMATION	Dimensions (box)	800 x 750 x 870 h mm
	Weight	120 kg
	Base with 3 wheels	-
ENGINE	Type	Honda GX390
IMPELLER	Diameter	330 mm with special cutting system
	Blades - numberss	4 welded
	Blades - thikness	4 mm
	Safety system with micro-switch	✓
HOSE	Diameter	180 mm
	Length	5 m
	Material	Poliuretanic
	Hose-holder bar	✓
	Circular section extendable tube bras with a wheel	✓
DISCHARGE	Adjustable	360°
TRANSMISSION	With double belt	✓

OT8-T1

GENERAL INFORMATION	Dimensions (box)	1240 x 810 x 1870 h mm
	Weight	120 kg
ENGINE		For tractor starting to 16 hp - 540 Rpm
IMPELLER	Diameter	330 mm
	Blades - numberss	4 welded
	Blades - thikness	4 mm
HOSE	Diameter	180 mm
	Length	5 m
	Material	Poliuretanic
	Hose-holder bar	-
	Circular section extendable tube bras with a wheel	✓
DISCHARGE	Adjustable	360°
TRANSMISSION	Made in Italy	Gear box with double belt

OLGA

Debris loader

Olga is a debris loader suitable for cleaning and vacuuming leaves, grass, and light debris from **parking lots, parks, campsites, streets, and courtyards**. Ideal for outfitting compactor vans, it is perfect for urban hygiene and quick clean-ups after events (concerts, carnivals, public gatherings, markets).



Employers of Agrinova technical office, will assist you on the planning the apply of Vacuum on your truck.

features

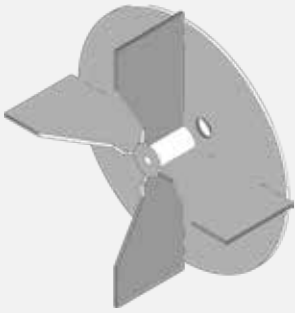

Impeller: Ø 330 mm; 4 blades 4 mm thickness. The impeller is connected directly to the motor shaft.



Hose: polyurethane hose for lightweight, flexibility and excellent wear resistance. Length 5m - Ø 180 mm; copper coiled to eliminate static charges



Tie hook and lift handle: suitable for many types of tail gates (customizable on request)



Safety device: limit switch to stop the impeller when the impeller shield is removed

optional



Lift truck: **code DT490DS**



Base with 3 wheels: **code OT120**



Kit hose holder squeezed section with 2 wheels, for hose 180 mm diameter, 35 mm width: **code AS80SC**

technical data

OLGA OT16B

GENERAL INFORMATION	Dimensions (box)	800 x 750 x 870 h mm
	Dimensions pallet (with 4 boxes)	800 x 1500 x 1870 h mm
	Weight	59 kg
	Base a 3 ruote	OPTIONAL cod. OT120
ENGINE	Base with 3 wheels	Briggs & Stratton serie 950
	Power	6,5 HP
IMPELLER	Diameter	330 mm
	Blades - number	4 welded
	Blades - thickness	4 mm
	Safety system with micro-switch	✓
HOSE	Diameter	180 mm
	Length	5 m
	Material	Poliuretanic
DISCHARGE		Fix
TRANSMISSION		Direct

dimensions

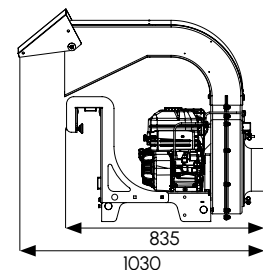
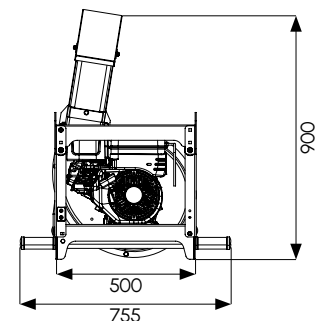

OSWALD

Outdoor vacuum

Oswald equipped with optional becomes a complete **system for the cleaning of parks, gardens and roads.**



- ✓ HIGH PERFORMANCE
- ✓ LOW NOISE EMISSIONS

features



Self-propelled differential: the differential is used in this model to increase manoeuvrability: when steering, the right and left-hand wheels can turn at different speeds.



Rear: 2 pneumatic;
Front: 1 pivoting (2 pivoting on brush version)



Impeller: with 4 x 4 mm steel radial blades.

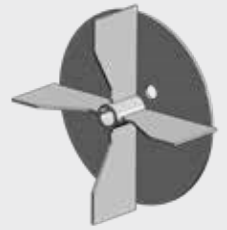

Housin obtained by pressing: 2 mm sheet metal.

Suction mouth profile: the profile of the polyethylene suction has been designed to facilitate the flow of leaves (inlet suction area: 700 x 90 mm).



Top-loading of the bags: to ensure full filling (230 lt capacity).

Manual regulation of suction: adjustable on 6 levels



OSWALD IS PERFECT

for vacuuming leaves, pine needles, pine cones and light waste.

other versions



Side brush in "SL-Version"

The side brush allows a larger cleaning, offering better performances of the machines, reducing working times.

Features:

- Diameter 45 cm
- Bristles in 1 mm PPL



Impeller with star-shaped knife "13 Version"

It is provided for those who have large amounts of leaves to suck up and want to optimize the capacity of the bag. The machine in this series have a star-shaped knife, which cut the leaves up before they enter the turbine. The use of this knife means that these units are **only suitable for suction of leaves** as the knife obstruct the passageway.

NOTE: suggested with OS13, the purchase of the Bag support trolley (AS450).

operator safety



The micro-switch placed in correspondence of the suction mouth, makes secure **fast opening required for checks and maintenance.**

optional

Make your oswald a suction system by choosing the **optionals that suit your needs.**

bags



AS978 powder dust cover (dust dump)



AS948 special bag for easy suction of wet leaves



AS958 bag (standard) recommended in dry climates

suction hoses



AS91203 - Ø 180 mm
Hose in POLYURETHANE Ø 180 | 5 m (very light and flexible).



AS404 - Ø 100 mm
Hose in PVC Ø 100 | 4 mt (not recommended for "version 13").

blower transformation kit



AS440 - composed of side exit nozzle and protection grid (not usable in models with side brush)



AS51220 - consisting of - protection grille, special curve and PVC tube diameter 100 mm

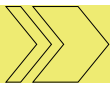

optional

other kit



AS65 - gravel kit Ø 260 mm
Gravel kit with pneumatic wheel
(not usable in models with side
brush).



AS455 - bag support trolley
Recommended when vacuuming
wet leaves, heavy material and
with "version 13".

→ **code AS450 for
Oskar model**



dimensions

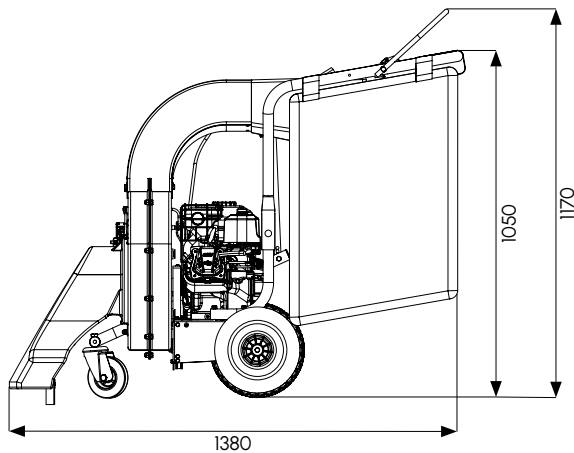
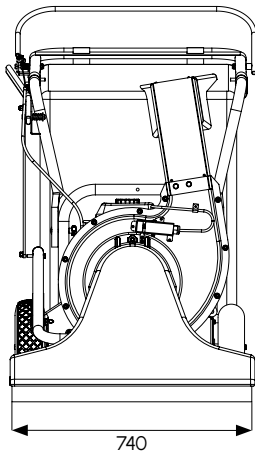

With brush

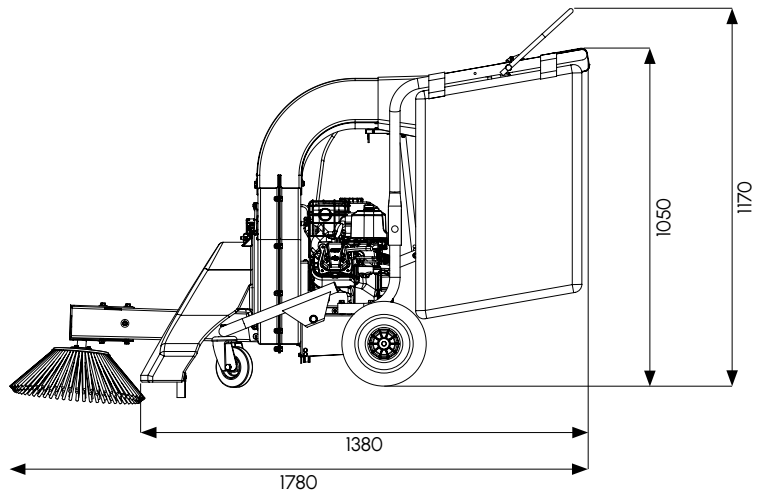
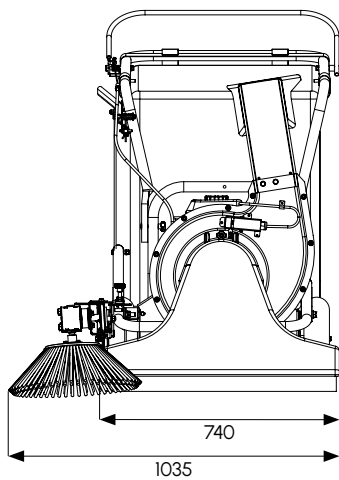

technical data

BASIC MODELS		OS10D3	OS10D2H
GENERAL INFORMATION	Dimensions (box)	790 x 690 x 720 h mm	790 x 690 x 720 h mm
	Dimensions pallet (with 4 boxes)	1400 x 800 x 1600 h mm	1400 x 800 x 1600 h mm
	Weight	71 kg (circa)	71 kg (circa)
	Plastic nozzle - dimensions	70 x 10 cm	70 x 10 cm
	Regulation of suction	On 6 positions	On 6 positions
ENGINE	Type	Briggs & Stratton serie 1450	Honda GX160
	Power	6,5 HP	5,5 HP
IMPELLER	Diameter	330 mm	330 mm
	Blades	4 radial steel 4 mm	4 radial steel 4 mm
	Safety micro-switch	✓	✓
DISCHARGE	Leaf discharge	At the top	At the top
	Bag	AS958	AS958
HANDLING SYSTEM	Self propelled	✓ With differential	✓ With differential
	Wheels	2 pneumatic + 1 pivoting	2 pneumatic + 1 pivoting

MODELS WITH - FRONTAL BRUSH "SL"		OS10D3 - SL	OS10D2H - SL
GENERAL INFORMATION	Weight	78 kg (about)	78 kg (about)
	With frontal brush	ø 450 mm - with belt transmission and steel gears	ø 450 mm - with belt transmission and steel gears
	Configuration	As OS10D3 (no the weight) with 2 pivoting wheels	As OS10D2H (no the weight) with 2 pivoting wheels

MODELS WITH- IMPELLER LEAF SHREDDER "13"		OS13D3	OS13D2H
GENERAL INFORMATION	Weight	73 kg	73 kg
	With leaf shredder	✓	✓
	Configuration	As OS10D3 (no the weight) with 2 pivoting wheels	As OS10D2H (no the weight) with 2 pivoting wheels

MODELS WITH - FRONTAL BRUSH "SL" AND LEAF SHREDDER "13"		OS13D3 - SL	OS13D2H - SL
GENERAL INFORMATION	Weight	78 kg	78 kg
	With frontal brush	ø 450 mm - with belt transmission and steel gears	ø 450 mm - with belt transmission and steel gears
	With leaf shredder	✓	✓
	Configuration	As OS10D3 (no the weight) with 2 pivoting wheels	As OS10D2H (no the weight) with 2 pivoting wheels

OSKAR

Vacuum leaf cleaner to push

Oskar was created for cleaning parks and streets, despite the absence of a side brush and shredder.



cleaning mission



dimensions

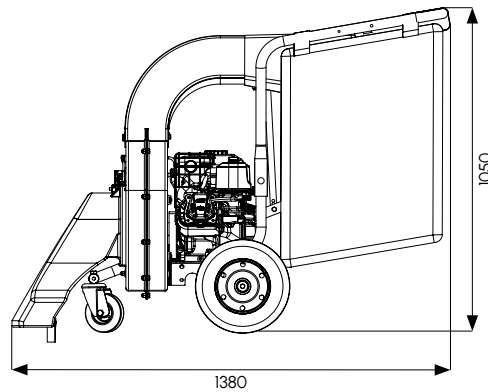
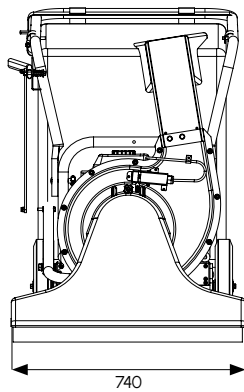

technical data

		OS10P
GENERAL INFORMATION	Dimensions (box)	790 x 690 x 720 h mm
	Dimensioni (pallet con 4 boxes)	1400 x 800 x 1600 h mm
	Weight	71 kg
	Polyethylene suction nozzle	70 x 10 cm
	Working height adjustment	On 6 positions
ENGINE	Type	Briggs & Stratton serie 950
TURBINA	Diameter	330 mm
	Blades - number	4
	Blades - thickness	4 mm
	Safety microswitch	✓
TUBO	Diameter	180 mm
	Lenght	5 m
	Material	Poliueretanic
SCARICO	Leaf discharge	At the top
	Bag capacity	230 l
HANDLING SYSTEM	Wheels	2 pneumatic + 1 pivoting
OPTIONAL		See Oswald optional



POWER RAK SCARIFIER

KES & S



JEREMY 95 CM

Towed lawn scarifier

Long lasting blade with anti-wear thermal treatment



Composed the scarifier suitable for your lawn

Line for the maintenance of parks, gardens and football yard.

For lawns and sports fields (95 cm)

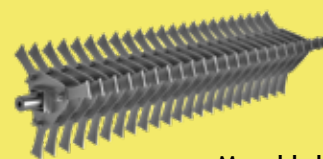

Movable knives

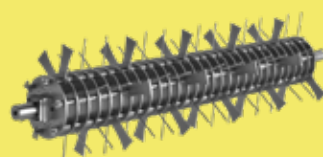

Spring and knives

It's the construction details that determine the quality of Agrinova scarifiers.

Agrinova knows that every lawn is different and should be treated according to its needs, so the scarifiers that it \ systems.

The know-how gained over many years of experience and comparison with the gardening sector experts led to the development of different working systems, which allow us to treat with maximum efficiency any kind of lawn.



strenghts



GOOD FOR RENTING

- > They are **handy but robust**
- > Professional engines that with **oil alert**
- > They have **quality belts**
- > They mounted wheels **with metal hub**
- > **Count-hours** on demand

- **The metal thickness** of the shell
- The types of **bearings**
- The type of **belts**
- The **type of steel chosen** to produce the cutting knives
- **Heat treatments to make them as strong and sharp** as long as possible and the wide range of types of machines, to meet the specific needs of the lawn to care.



work system

rotor shaft with movable knives

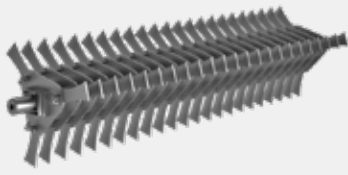

System allowing: verticutting, which performs a series of cuts in the soil from a recommended depth of half a cm; removal of felt by skimming the soil

Choice of blade thickness



2,5 mm
(as standard)



1,2 mm
(on demand) for
blade step 30 or
40 mm

Floating system: if the blades hit an obstacle typically found in gardens (such as surface roots of plants, sprinkler heads, curbs, etc.), they do not get **damaged, as they rotate** around their center and return to their working position due to the **centrifugal force generated by the 3000 RPM rotation.**

Speciale campo sportivo: ideale per campo sportivo l'albero con coltelli flottanti ravvicinati (90 blades).

shaft with springs and knives

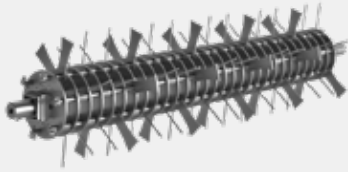

This type of cutting system requires little **engine power, and** must be carried out at the lowest possible speed.

How to use

Often moss and felt accumulations are created on the lawn due to water stagnation and the constant presence of mowing left on the ground using the mulching system. Before aerating the grass roots and the first layer of soil, the felt layer must be cleaned.

The grass layer must be combed out superficially using soft tips like those of a spring. However, since this is done at high speed, with considerable power provided by the internal combustion engine, it is necessary to give rigidity to the cutting system by interspersing the springs with movable knives.

This prevents the system from pushing too hard on the spring stalks and thus preventing breakage.

construction details



Double-belt transmission.

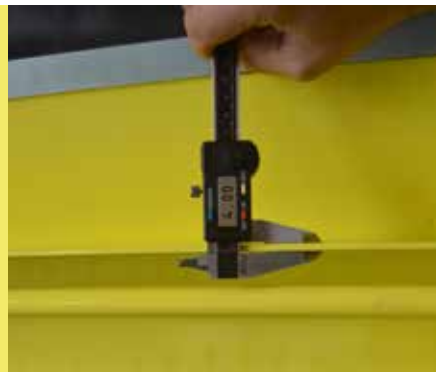

The shell is very robust: 4 mm thickness - shell weight 35 kg.



Balancing ballast: to balance the motor weight on one side of the machine, there is a different one on the opposite side depending on the motor chosen.

construction details



B&S or Honda engine - Powerful and reliable - Choice of 9 or 13 HP. Perfectly sized for these machines.



The cutting system is supported by two cast iron supports and two ball bearings. The grease nipple is easy to reach during maintenance.



Soft rubber wheels that do not damage the grass and semi-filled wheels that do not deflate or puncture. With ball bearings and mounted on a 20 mm diameter axle.



Working height adjustment system: from a seated position on the tractor/quad, by operating the lever, the machine can be raised so that the knives do not touch the ground.



Adjustable drawbar hitch for easy coupling to any type of tractor or quad bike.

work system

JEREMY

GENERAL INFORMATION	Working width	95 cm
	Dimensions (box)	1230 x 800 x 860 h mm
	Dimensions pallet	(2 boxes) 1230 x 800 x 1720 h mm
	Weight	127 kg (per Cod.JU949) - 135 kg (per Cod.JU950-H)
	Bearings	Cast iron with supports
ENGINE	Type	Briggs & Stratton serie I450 - Cod. JU949 Honda GX390 (13 HP) - Cod JU950-H
	Power	9 HP
HANDLING SYSTEM	Wheels	2 in anti-puncture rubber, mounted on ball bearings (on a 20 mm diameter axle)
WORK SYSTEM	Standard	rotor shaft with movable knives thickness 2,5 mm (step 40) (nr 69 blades) - Cod AR945
	Optional	rotor shaft with movable knives thickness 2,5 mm (step 30) (nr 90 blades) - Cod AR946 Shaft with spring and blades (nr 29 blades + 58 springs) - Cod AR947
	Transmission	2 belts

JEREMY 70 CM

Power rake for tractor

Long lasting blade with anti-wear thermal treatment



Composed the scarifier suitable for your lawn

Line for the maintenance of parks, gardens and football yard.

For lawns and sports fields (70 cm)

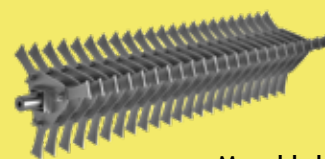

Movable knives

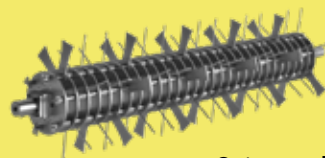

Spring and knives

It's the construction details that determine the quality of Agrinova scarifiers.

Agrinova knows that every lawn is different and should be treated according to its needs, so the scarifiers that it \ systems.

The know-how gained over many years of experience and comparison with the gardening sector experts led to the development of different working systems, which allow us to treat with maximum efficiency any kind of lawn.



strenghts



GOOD FOR RENTING

- The metal thickness of the shell
- The types of bearings
- The type of belts
- The type of steel chosen to produce the cutting knives
- Heat treatments to make them as strong and sharp as long as possible and the wide range of types of machines, to meet the specific needs of the lawn to care.



work system

rotor shaft with movable knives

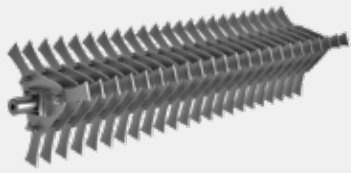

System allowing: verticutting, which performs a series of cuts in the soil from a recommended depth of half a cm; removal of felt by skimming the soil

Choice of blade thickness



2,5 mm
(as standard)



1,2 mm
(on demand) for
blade step 30 or
40 mm

Floating system: if the blades hit an obstacle typically found in gardens (such as surface roots of plants, sprinkler heads, curbs, etc.), they do not get **damaged, as they rotate** around their center and return to their working position due to the **centrifugal force generated by the 3000 RPM** rotation.

shaft with springs and knives

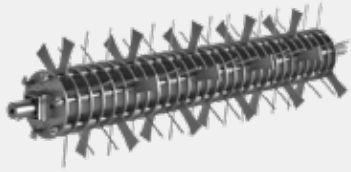

This type of cutting system requires **little engine power**, and must be carried out at the lowest possible speed.

How to use

Often moss and felt accumulations are created on the lawn due to water stagnation and the constant presence of mowing left on the ground using the mulching system. Before aerating the grass roots and the first layer of soil, the felt layer must be cleaned.

The grass layer must be combed out superficially using soft tips like those of a spring. However, since this is done at high speed, with considerable power provided by the internal combustion engine, it is necessary to give rigidity to the cutting system by interspersing the springs with movable knives.

This prevents the system from pushing too hard on the spring stalks and thus preventing breakage.

construction details

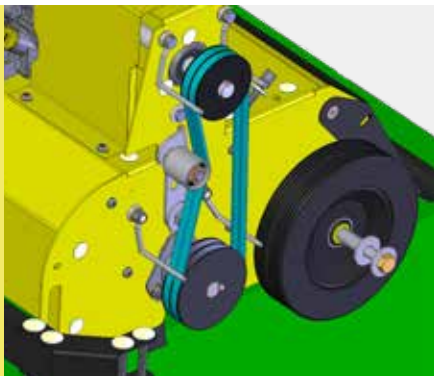

Double-belt transmission.



Central engine position for optimum weight balance.



2 front pivoting solid rubber wheels with sheet metal rims.

construction details



200 mm diameter solid rubber wheels with sheet metal rims.



The cutting system is supported by two cast iron supports and two high-quality ball bearings.



Automatically operated lifting handle for the cutting system.

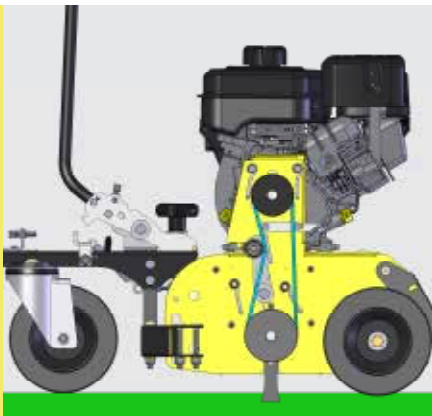

Belts in working position.

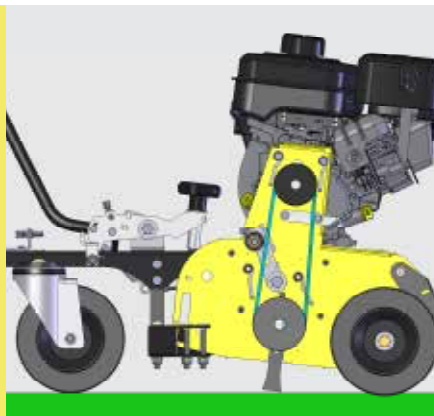

Belts in rest position.

technical data

JU70B2-T

GENERAL INFORMATION	Working width	70 cm
	Dimensions (box)	1230 x 800 x 860 h mm
	Dimensions pallet	(2 pallet boxes) 1230 x 800 x 1720 h mm
	Weight	68 kg
	Bearings	Cast iron with supports
ENGINE	Type	Briggs & Stratton series 950 - Cod. JU70B2-T
	Power	6,5 HP
HANDLING SYSTEM	Wheels	200 mm diameter rubber puncture-proof with metal rim. 2 fixed rear + 2 pivoting
WORK SYSTEM	Standard	Rotor shaft with movable knives thickness 2,5 mm (step 40) (nr 48 blades) - Cod AC700
	Optional	Shaft with spring and blades (nr 21 blades + 44 molle) - Cod AL71
	Transmission	2 belts

JULIO

Power rake

Long lasting blade with anti-wear thermal treatment



Composed the scarifier suitable for your lawn

Line for the maintenance of parks, gardens and football yard.

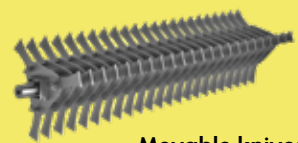

Movable knives

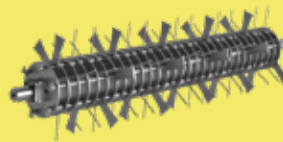

Spring and knives



Fixed knives



NEW!

Screw-operated depth adjustment by key (on request)



GOOD FOR RENTING

To ensure the regeneration and greening of the grass layer in spring and autumn, it is advisable to remove excess thatch and vertically slice the surface layer of the soil. This operation ensures proper oxygenation of the lawn and is **carried out with an aerator (also known as a scarifier).**

main features

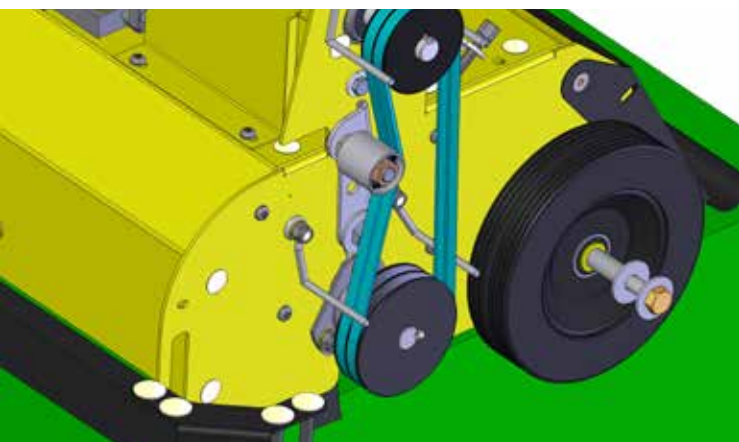

Belt drive

- **Engine in central position**
- **Pressed steel flange bearing unit**
- **2 belts**
- **Wheels with metallic hub**
- **Standard working system:** movable knives
- **Optional working system:** fix knives, spring and knives
- **Height adjustment knob, with key lock (on request)**

work system

JU70B2

GENERAL INFORMATION	Working width	70 cm
	Dimensions (box)	620 x 670 x 660 h mm
	Dimensions pallet	(with 4 boxes) 1260 x 800 x 1500 h mm
	Weight	63 kg
ENGINE	Bearings	2 with sheet metal support
	Type	Briggs & Stratton 950 series (positioned against the body)
HANDLING SYSTEM	Power	6,5 HP
	Wheels	4 with metal rim
WORK SYSTEM	Standard	Rotor shaft with movable knives thickness 2,5 mm (step 40) (nr 48 blades)
	Transmission	2 belts

JOSEF

Self propelled power rake

Long lasting blade with anti-wear thermal treatment



Composed the scarifier suitable for your lawn

Line for the maintenance of parks, gardens and football yard.

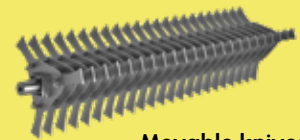

Movable knives

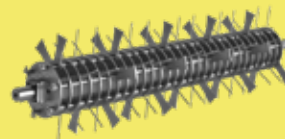

Spring and knives



Fixed knives

It's the construction details that determine the quality of Agrinova scarifiers.

Agrinova knows that every lawn is different and should be treated according to its needs, so the scarifiers that it \ systems.

The know-how gained over many years of experience and comparison with the gardening sector experts led to the development of **different working systems, which allow us to treat with maximum efficiency any kind of lawn.**



strenghts



GOOD FOR LANDSCAPERS

- **The self-propelled power rake facilitates and speeds up** ploughing times. The operator, after actuating the large, sturdy lever at the end of the handlebars, only has to follow and guide the Power rake, which, with its own propulsion, can overcome climbs and inclines
- **Variable speed** makes it possible to: adapt the machine to the conditions of the lawn to be ploughed; speed up movement between two work areas; facilitate loading onto vehicles

- **The metal thickness** of the shell
- The types of **bearings**
- The type of **belts**
- The **type of steel chosen** to produce the cutting knives
- **Heat treatments to make them as strong and sharp** as long as possible and the wide range of types of machines, to meet the specific needs of the lawn to care.



1. Honda engine
2. Heavy duty chassis 4 mm thickness steel
3. Cover belt casing
4. Lever for depth regulation
5. Blades engaging lever
6. Self propelling lever
7. Speed regulation lever
8. Tires 280 mm diametre
9. Speed accelerator

work system

rotor shaft with movable knives

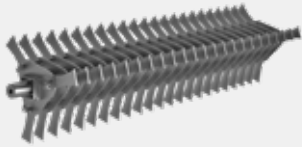

A system that allows: verticutting, which performs a series of cuts in the soil from a recommended depth of half a cm; removal of felt by skimming the soil.
(Cod. ACU600: 42 knives thickness 2,5 mm)

Choice of blade thickness



2,5 mm
(as standard)



1,2 mm
(on demand) for
blade step 30 or
40 mm

Floating system: if the blades hit an obstacle typically found in gardens (such as surface roots of plants, sprinkler heads, curbs, etc.), they do not get **damaged, as they rotate** around their center and return to their working position due to the **centrifugal force generated by the 3000 RPM** rotation.

shaft with springs and knives

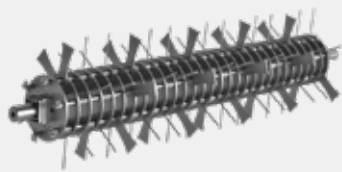

This type of cutting system requires **little engine power, and must** be carried out at the lowest possible speed.

How to use

Often moss and felt accumulations are created on the lawn due to water stagnation and the constant presence of mowing left on the ground using the mulching system. Before aerating the grass roots and the first layer of soil, the felt layer must be cleaned. The grass layer must be combed out superficially using soft tips like those of a spring. However, since this is done at **high speed, with considerable power provided** by the internal combustion engine, it is necessary to give rigidity to the cutting system by interspersing the springs with movable knives. This prevents the system **from pushing too hard on the spring stalks** and thus preventing breakage.

shaft with fixed blades

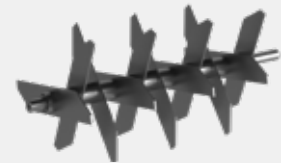

Cod. ACU610: 12 knives thickness 2.5 mm

What is it

Verticutting is literally vertical cutting, the operation of creating **perfectly precise and rigid furrows in the grass**. The roots of the grass will be cut cleanly, without being torn or damaged. The furrow will have a constant depth and, if correctly recorded by the operator, 0,5/1 cm, which is ideal for oxygenating the soil.

construction details



Tires: 4 tires 280 mm diameter, 100 mm wide



Chassis **4 mm thickness**



Adjusting levers: 7 for blades engaging 7 for self propelling 1 for speed regulation (updating)

construction details



Speed controller: achieved with a variable-diameter pulley. Speed from 0 to 4.5 km/h.



Differential system: obtained with freewheel sprocket and chain drive



Good stability thanks central position of engine



Heavy duty gear boxes

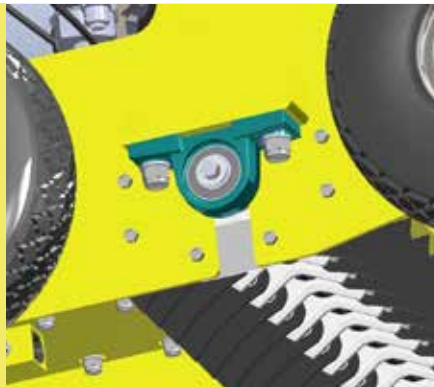

Bearings with cast-iron support and grease nipple make disassembly of the cutting shaft fast.



Cutting depth regulation: 11 positions.

technical data

		JO60H4
GENERAL INFORMATION	Weight	90 kg
	Work Configuration - Dimensions	800 x 1150 x 1070 h mm
	Transport Configuration - Dimensions	800 x 1150 x 750 h mm
	Chassis	Made of 4 mm welded and powder-coated sheet metal
ENGINE	Type	Honda GP200
	Main Features	4-stroke, air-cooled, OHV (overhead valve), oilguard
	Displacement	Single-cylinder 196 cc
	Tank Capacity	3,1 l
	Oil Capacity	0,6 l
	Power	4,1 Kw@3600 RPM, Ref. SAE J1349
WORK SYSTEM	Nominal working width/body width	60 cm
	Standard	Rotor shaft with movable knives thickness 2,5 mm (step 40) (nr 42 blades) - Cod. ACU600
	Optional	Shaft with spring and blades (step 29) (nr 78 blades + 36 springs) - Cod AL670 Shaft Fixed knives thickness 2,5 mm (nr 12 blades) - Cod ACU610
	Knife shaft drive	1 section B belt, with high-performance coating
	Knife shaft bearings	Industrial cast iron bearings with grease nipple
	Working depth adjustment	11 clicks, with manual lever
TRANSMISSION	Drive	Rear
	Speed regulator	Continuous, variable pulley drive
	Transmission	Differential with freewheel sprockets and final chain drive
	Front/rear wheels	Pneumatic, Ø 280 mm, on ball bearings
	Max. speed	4,5 km/h

JURGEN

Power rake

Long lasting blade with anti-wear thermal treatment



Composed the scarifier suitable for your lawn

Line for the maintenance of parks, gardens and football yard.

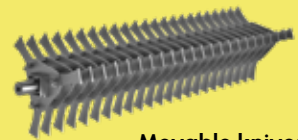

Movable knives

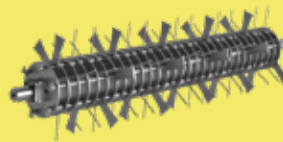

Spring and knives



Fixed knives



NEW! Screw-operated depth adjustment by key (on request)

Agrinova knows that every lawn is different and must be treated according to its needs, which is why the scarifiers it produces offer **a wide variety of cutting systems**. The know-how accumulated over many years of experience and discussions with experts in the gardening sector has led to the **development of various work systems that allow any type of lawn to be treated with maximum effectiveness**.



Strengths



- **The metal thickness** of the shell
- The types of **bearings**
- The type of **belts**
- The **type of steel chosen** to produce the cutting knives
- **Heat treatments to make them as strong and sharp** as long as possible and the wide range of types of machines, to meet the specific needs of the lawn to care.

GOOD FOR RENTING

- › They are **handy but robust**
- › Professional engines that with **oil alert**
- › They have **quality belts**
- › They mounted wheels **with metal hub**
- › **Count-hours** on demand

To ensure the regeneration and greening of the grass layer in spring and autumn, it is advisable to remove excess thatch and vertically slice the surface layer of the soil. This operation ensures proper oxygenation of the lawn and is **carried out with an aerator (also known as a scarifier)**.



1. Honda or B&S engine
2. Robust steel shell (3 mm)
3. Carter belt cover
4. Screw-operated depth adjustment (up to 25-30 mm with unworn blades)
5. Lever (to stop the movement of the knives on)
6. Wheel swing section
7. Wheels with metal hub
8. Height adjustment system protection mask
9. Cast Iron Pillow Block Bearings with Grease Zerk

work system

rotor shaft with movable knives

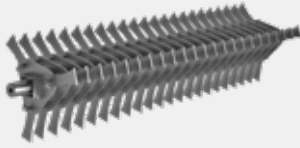

A system that allows: verticutting, which performs a series of cuts in the soil from a recommended depth of half a cm; removal of felt by skimming the soil.

Choice of blade thickness



2,5 mm
(as standard)

1,2 mm
(on demand) for
blade step 30 or
40 mm

Floating system: if the blades hit an obstacle typically found in gardens (such as surface roots of plants, sprinkler heads, curbs, etc.), they do not get **damaged, as they rotate** around their center and return to their working position due to the **centrifugal force generated by the 3000 RPM** rotation.

shaft with springs and knives

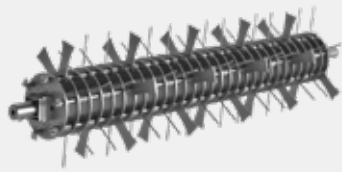

This type of cutting system requires **little engine power, and must** be carried out at the lowest possible speed.

How to use

Often moss and felt accumulations are created on the lawn due to water stagnation and the constant presence of mowing left on the ground using the mulching system. Before aerating the grass roots and the first layer of soil, the felt layer must be cleaned. The grass layer must be combed out superficially using soft tips like those of a spring. However, since this is done at **high speed, with considerable power provided** by the internal combustion engine, it is necessary to give rigidity to the cutting system by interspersing the springs with movable knives. This prevents the system **from pushing too hard on the spring stalks** and thus preventing breakage.

shaft with fixed blades

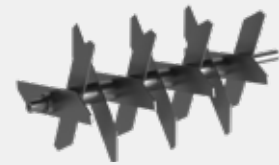

What is it

Verticutting is literally vertical cutting, the operation of creating **perfectly precise and rigid furrows in the grass**. The **roots** of the grass will be cut cleanly, without being torn or damaged. The furrow will have a constant depth and, if correctly recorded by the operator, 0,5/1 cm, which is ideal for oxygenating the soil.

construction details



Recoiling bag (optional)



Easy to transport even with small cars

construction details



Double toothed belt drive (made in Germany) to ensure many hours of work (ideal for rental purposes). Metal belt tensioning drive, mounted on double bearings with 60 mm diameter.



Oscillating bearings on cast iron support and greasing point.



Oscillating wheel axle: the cutting system always remains parallel to the ground (even on slopes).

work system

		JURGEN	JURGEN
ENGINE - CODE SCARIFIER	Working width	45 cm	60 cm
		Briggs & Stratton series 950 Cod. JU47B2-RM Honda GX160 - Cod. JU47H-RM	Briggs & Stratton series 950 Cod. JU603B2-RM Honda GX160 - Cod. JU603H-RM
WORK SYSTEM	Toothed belts	2	2
	Standard	Shaft with mobile blades 2,5 mm thickness (step 40 mm) Cod. ACO (33 Blades)	Shaft with mobile blades 2,5 mm thickness (step 40 mm) Cod. AC2 (42 Blades)
		Shaft with mobile blades 2,5 mm thickness (step 30 mm) Cod. AR245	Shaft with mobile blades 2,5 mm thickness (step 30 mm) Cod. AR260
	Optional	Rotor shaft with movable knives thickness 1.2 mm (step 40) Cod. ACOS	Rotor shaft with movable knives thickness 1.2 mm (step 40) Cod. AC2S
		Rotor shaft with movable knives Thickness 1.2 mm (step 30) Cod. AR252	Rotor shaft with movable knives Thickness 1.2 mm (step 30) Cod. AR261
		Shaft with fixed blades Thickness 2.5 mm (step 40) Cod. AR305 (15 Blades)	Shaft with fixed blades Thickness 2.5 mm (step 40) Cod. AR301 (19 Blades)
		Shaft with fixed blades Thickness 2.5 mm (step 30) Cod. ACOF2	Shaft with fixed blades Thickness 2.5 mm (step 30) Cod. AC2F2
		Shaft with fixed blades Thickness 1.2 mm (step 30) Cod. ACOF	Shaft with fixed blades Thickness 1.2 mm (step 30) Cod. AC2F
		Shaft with fixed blades Thickness 1.2 mm (step 40) Cod. ACOF1	Shaft with fixed blades Thickness 1.2 mm (step 40) Cod. AC2F1
		Shaft with spring and blades - Cod. AL48	Shaft with spring and blades - Cod. AL61
Weight		53 kg	58 kg
GENERAL INFORMATION	Dimensions (box)	620 x 670 x 660 h cm	750 x 670 x 660 h cm
	Dimensions pallet	(4 boxes) 1260 x 800 x 1500 h cm	(4 boxes) 1360 x 800 x 1500 h cm
	Bag	Optional (on request) Cod. AR370	Optional (on request) Cod. AR371
	Wheels	4 with metal rim	4 with metal rim

JEFF

Power rake

Long lasting blade with anti-wear thermal treatment



Composed the scarifier suitable for your lawn

Line for the maintenance of parks, gardens and football yard.

**For lawns and sports fields
(38 - 45 cm)**

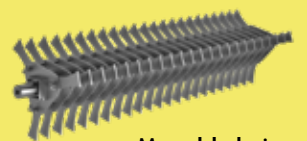

Movable knives

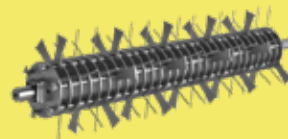

Spring and knives



Fixed knives

It's the construction details that determine the quality of Agrinova scarifiers.

Agrinova knows that every lawn is different and should be treated according to its needs, so the scarifiers that it \ systems.

The know-how gained over many years of experience and comparison with the gardening sector experts led to the development of **different working systems, which allow us to treat with maximum efficiency any kind of lawn.**



strenghts



- The **metal thickness** of the shell
- The types of **bearings**
- The type of **belts**
- The **type of steel chosen** to produce the cutting knives
- **Heat treatments to make them as strong and sharp** as long as possible and the wide range of types of machines, to meet the specific needs of the lawn to care.

HIGH QUALITY SCARIFIER

> To ensure the regeneration and greening of the grass layer in spring and autumn, it is advisable to remove excess thatch and vertically slice the surface layer of the soil. This operation ensures proper oxygenation of the lawn and is **carried out with an aerator (also known as a scarifier).**



1. Engine
2. Robust steel shell (3 mm)
3. Carter belt cover
4. Screw-operated depth adjustment
5. Lever (to stop the movement of the knives on)
6. Wheel swing section
7. Cast Iron Pillow Block Bearings

work system

rotor shaft with movable knives

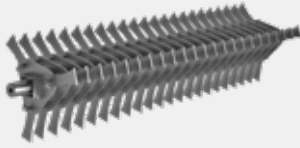

A system that allows: verticutting, which performs a series of cuts in the soil from a recommended depth of half a cm; removal of felt by skimming the soil.

Choice of blade thickness



2,5 mm
(as standard)

1,2 mm
(on demand) for
blade step 30 or
40 mm

Floating system: if the blades hit an obstacle typically found in gardens (such as surface roots of plants, sprinkler heads, curbs, etc.), they do not get **damaged, as they rotate** around their center and return to their working position due to the **centrifugal force generated by the 3000 RPM** rotation.

shaft with springs and knives

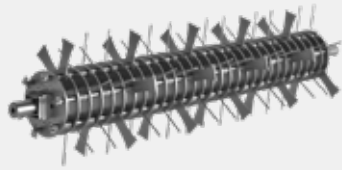

This type of cutting system requires **little engine power, and must** be carried out at the lowest possible speed.

How to use

Often moss and felt accumulations are created on the lawn due to water stagnation and the constant presence of mowing left on the ground using the mulching system. Before aerating the grass roots and the first layer of soil, the felt layer must be cleaned. The grass layer must be combed out superficially using soft tips like those of a spring. However, since this is done at **high speed, with considerable power provided** by the internal combustion engine, it is necessary to give rigidity to the cutting system by interspersing the springs with movable knives. This prevents the system **from pushing too hard on the spring stalks** and thus preventing breakage.

shaft with fixed blades



What is it

Verticutting is literally vertical cutting, the operation of creating **perfectly precise and rigid furrows in the grass**. The roots of the grass will be cut cleanly, without being torn or damaged. The furrow will have a constant depth and, if correctly recorded by the operator, 0,5/1 cm, which is ideal for oxygenating the soil.

construction details



Recoiling bag (optional)



Easy to transport even with small cars

construction details



Double toothed belt drive (for 45 and 60 cm models). Steel drive on double bearing to ensure high speed (long service life).



Oscillating wheel axle: the cutting system always remains parallel to the ground (even on slopes).

technical data

		JE38R	JE47B2
ENGINE - CODE SCARIFIER	Working width	38 cm	45 cm
		Briggs & Stratton series E550 Cod. JE38R	Briggs & Stratton series 950 Cod. JE47B2
WORK SYSTEM	Toothed belts	1	2
	Standard	Shaft with mobile blades 2,5 mm thickness (step 40 mm) Cod. AR1512	Shaft with mobile blades 2,5 mm thickness (step 40 mm) Cod. ACO (33 blades)
		Shaft with mobile blades 2,5 mm thickness (step 30 mm) Cod. AR245	Shaft with mobile blades 2,5 mm thickness (step 30 mm) Cod. AR245
	Not available	Rotor shaft with movable knives thickness 1.2 mm (step 40) Cod. ACOS	
	Not available	Rotor shaft with movable knives thickness 1.2 mm (step 30) Cod. AR252	
	Optional	Shaft with fixed blades thickness 2.5 mm (step 40) Cod. AR450 (9 coltelli)	Shaft with fixed blades thickness 2.5 mm (step 40) Cod. AR305 (11 coltelli)
		Shaft with fixed blades thickness 2.5 mm (step 30) Cod. AR450F2	Shaft with fixed blades thickness 2.5 mm (step 30) Cod. ACOF2
		Not available	Shaft with fixed blades thickness 1.2 mm (step 30) Cod. ACOF
		Not available	Shaft with fixed blades thickness 1.2 mm (step 40) Cod. ACOF1
	Not available	Shaft with spring and blades - Cod. AL48 (14 blades / 28 springs)	
GENERAL INFORMATION	Weight	36,5 kg	54 kg
	Dimensions (box)	660 x 530 x 630 h cm	620 x 670 x 660 h cm
	Dimensions pallet	6 pallet boxes 1200 x 800 x 2100 h cm	4 pallet boxes 1260 x 800 x 1500 h cm
	Bag	Optional (on request) Cod. AR338	Optional (on request) Cod. AR370
	Wheels	4 plastic with ball bearings	4 with metal rim

AGRINOVA

Ceccato-Mantovani

Products are subject to technical evolution, and this catalog may not be fully up to date. The data shown in the tables, photos, and images are intended for informational purposes only and are not binding. AGRINOVA S.r.l. reserves the right to make changes to its products at any time and without prior notice, without any obligation to extend these changes to machines already delivered. All photos, images, drawings, tables, and data are the property of AGRINOVA S.r.l., and any reproduction, even partial, is strictly prohibited without written authorization.

AGRINOVA
Ceccato-Mantovani

Via 24 Maggio, 26, 35010
Curtarolo PD

P.I. 04095710283

+39 049 574 2645
agrinova@agrinova-italia.it

Spare parts required:
parts@agrinova-italia.it

www.agrinova-italia.it

gardening machines