



LONG LIFE POWERFUL  
PROFESSIONAL GARDEN SOLUTIONS

# OLYSSE

## DEBRIS LOADER

Olysse has been designed to meet the needs of municipal, utility companies that deal with road, highway and park cleaning.



To be applied on  
Agricultural trailer



Compactor truck, dump truck, tanks



Employers of AgriNova technical office, will assist you on the planning the apply of Vacuum on your truck..



# OLYSSE

## Debris loader

### DIMENSIONS:

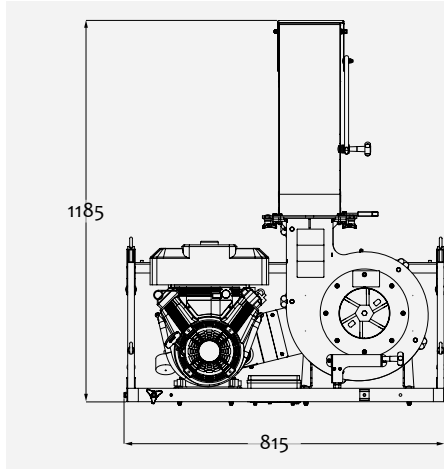

WEIGHT: 170Kg

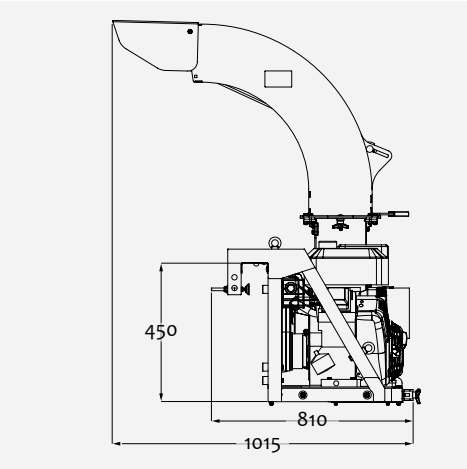

### IMPELLER:

- $\varnothing$  400 mm
- 6 blades of 10 mm thickness and 155 mm height

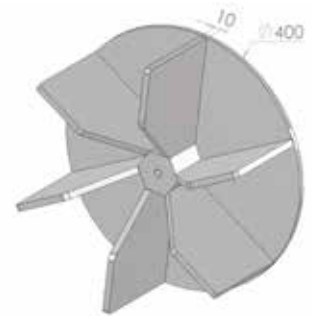

### ENGAGEMENT:

Suitable for many kinds of side (customized on request)



### TUBE:

- Lightweight, flexible polyurethane with a coiled, antistatic spiral ramata
- Length: 5 m or 200 mm
- With ergonomic handle
- Comfortable tube holder with one wheel (standard) or with two (optional) wheels, code AS8009



### HOUSING:

Seal dual-walled easy to remove

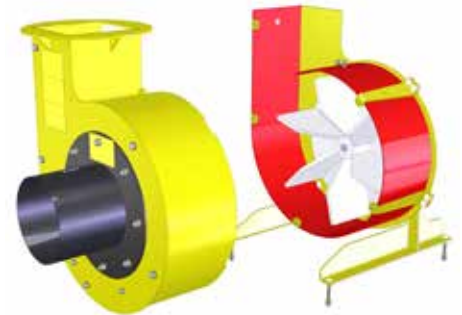

### MOTOR:

Powerful electric-start Briggs & Stratton Vanguard 18 hp engine



### DISCHARGE HOSE:

- 360° Swivelling
- Adjustable deflector with handle-olabile con maniglia



### TRANSMISSION:

Double belt transmission and centrifugal clutch



# OPTIONALS AVAILABLE

## COD. OL1300 - HUMIDIFIER KIT FOR DUST SUPPRESSION

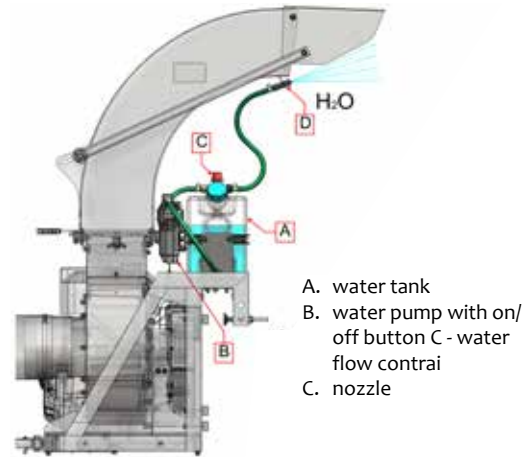

## Cod. OL950 - MANUAL HYDRAULIC FORKLIFT FOR THE LIFTING AND COUPLING OF THE SIDE OLYSSEA

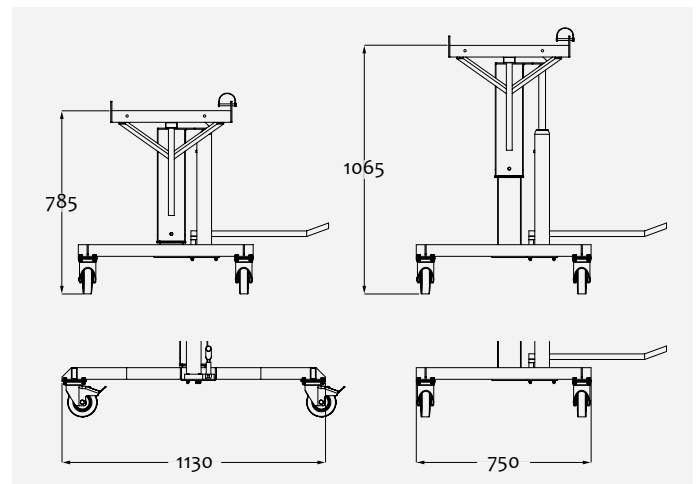

## NEW OPTIONALS

KIT HOSE HOLDER SQUEEZED SECTION WITH 2 WHEELS, FOR HOSE 180 mm DIAMETRE, 35 cm WIDTH cod. AS81SC



KIT HOSE HOLDER CIRCULAR SECTION DIAMETRE 180 mm WITH 2 WHEELS code AS8009



ADJUSTMENT ON 8 POSITIONS

### Technical data

		OL18
GENERAL INFORMATION	Dimensions	1708 x 1093 x 1900 h mm
	Peso	170 kg
ENGINE	Type	Briggs & Stratton - Vanguard
	Power	18 hp
	Displacement	V-Twin
IMPELLER	Diameter	400 mm
	Blades - number	6
	Blades - thickness	10 mm
	Steel dual-walled	✓
	Safety system with micro-switch	✓
HOSE	Diameter	200 mm
	Length	5 m
	Material	Polyurethane
	Hose-holder bar	✓
DISCHARGE CHUTE	Adjustable	360°
TRANSMISSION	double belt transmission and centrifugai clutch	✓
OPTIONAL		
Kit humidifier		OL1300
Manual hydraulic forklift		OL950
Kit hose holder circular section diametre 180 mm with 2 wheels		AS8009
Kit hose holder squeezed section with 2 wh eels, for hose 180 mm diametre, 35 cmwidth		AS81SC
Street chassis		Contact us for information

ALSO AVAILABLE ON HOMOLOGABLE STREET CHASSIS

*(Street chassis model of your choice)*

